

From Karolinska Institutet
Department of Medical Laboratory Sciences and Technology
Division of Medical Engineering

Respiratory Drive Assessment

An evaluation of the breath-by-breath
occlusion pressure method in man

By
Lars Gösta Hellström



Stockholm 2002

RESPIRATORY DRIVE ASSESSMENT - An evaluation of the
breath-by-breath occlusion pressure method in man
© Lars Gösta Hellström 2002

Division of Medical Engineering, Karolinska Institutet,
Novum, SE-141 86 Huddinge

ISBN 91-7349-272-8

Printed by Universitetsservice US AB Stockholm

To my family

Then the LORD God formed man of dust from the
ground
and breathed into his nostrils the breath of life;
and man became a living being.

Genesis 2:7

So long as men can breathe or eyes can see,
So long lives this, and this gives life to thee.

Shakespeare, Sonnet 18

Be inspired

Contents

Abstract	5
Publications	7
Abbreviations and words	8
Preface	9
Principal aims of the project.....	10
<i>Specific aims</i>	10
Background	11
<i>Physiology of breathing</i>	11
<i>Assessment of inspiratory activity</i>	20
<i>Provocation of ventilatory adjustments</i>	28
<i>Medical treatment and breathing</i>	34
<i>Disease and breathing</i>	37
Methods and materials	42
<i>Setting</i>	42
<i>Direct measurements</i>	42
<i>P_{0.1} and calculations</i>	44
<i>Equipment</i>	47
<i>Subjects and procedures</i>	53
<i>Challenges to breathing</i>	54
Results and discussion.....	58
<i>Characteristics of breathing</i>	58
<i>Equipment</i>	59
<i>Mechanical loading</i>	62
<i>Carbon dioxide sensitivity</i>	64
<i>Effect of drugs</i>	67
<i>Disease and breathing</i>	68
Conclusions.....	72
Acknowledgements	74
<i>Grants</i>	75
References	76
Original papers:	91

Abstract

A simplified concept of respiratory drive is to consider it as the integrated “output” from the CNS to the respiratory “pump” muscles. This drive is a result of a complex central respiratory pattern generation, and can in abnormal situations, *e.g.* of pathological or pharmacological origin, be altered.

The aim of this thesis was to develop devices and methods for assessment of respiratory drive in man, and to evaluate the method in clinical and experimental studies.

A modified breath-by-breath $P_{0.1}$ measurement technique based on occlusion pressure was designed. Three generations of dedicated devices for assessment of respiratory drive were built, and a ventilator was further adapted for the technique. Several methods for measuring ventilatory adjustment to disturbed breathing (chemical or mechanical stimulation) were evaluated, and the technique was also used to study pathologically and pharmacologically altered breathing. Comparisons between equipment, methods and medical conditions were performed as group comparisons between patients and healthy subjects.

The proposed technique to measure $P_{0.1}$ breath-by-breath can be used without influencing the breathing pattern. As $P_{0.1}$ shows a high temporal variability, this continuous breath-by-breath measurement should be preferred to intermittent measurement on single breaths. When breathing on a ventilator, $P_{0.1}$ measurement can be compromised by mechanical loading of the equipment.

Breathing on a ventilator was shown to be compatible with all the tested methods for provocation of breathing. Transient response to short pulses of CO_2 is a patient-friendly possibility to test chemosensitivity, in comparison with steady-state and rebreathing technique. A ventilator is especially suited for measurement of sensitivity to mechanical stimulation.

Clinical application of the technique was performed in three studies with the following results: 1) Ketamine reverses the

depressive effect on ventilation of alfentanil. 2) COPD patients with nocturnal hypoxemia preserve their drive and chemosensitivity unaltered in at least one year without development of daytime hypoxemia. 3) Growth hormone profoundly improves the hypoventilation and chemosensitivity in Prader-Willi patients.

It is concluded that respiratory drive assessment can give added diagnostic or therapeutic value in several specific medical situations, and can be accomplished without a complicated or invasive technique.

Publications

This thesis is based on the following papers, referred to by their roman numerals.

- I **Breath-by-breath determination of inspiratory occlusion pressure**
Larsson H, Hellström LG and Linnarsson D, 1993
Clin Physiol **13**, 133-142
- II **Implementation of a Respiratory Drive Monitor on a Servo Ventilator**
Hellström LG, Larsson H and Linnarsson D, 1999
J Clin Monit and Comp **15**, 163-170
- III **Respiratory sensitivity to small mechanical stimuli, assessed by spontaneously breathing on a ventilator.**
Hellström LG and Persson J, 2001
Proc 23rd Ann Int Conf IEEE Eng Med Biol Soc
- IV **Respiratory sensitivity to carbon dioxide assessed by spontaneously breathing on a ventilator**
Hellström LG and Persson J, 2002
Manuscript
- V **Ketamine Antagonizes Alfentanil-induced Hypoventilation in healthy Male Volunteers**
Persson J, Scheinin H, Hellström LG, Björkman S, Götharson E and Gustafsson LL 1999
Acta Anaesthesiol Scand **43**, 744-752
- VI **Sleep quality, carbon dioxide responsiveness and desaturation patterns in nocturnal hypoxemia due to chronic obstructive lung disease (COLD) without daytime hypoxemia**
Sandek K, Andersson T, Bratel T, Hellström G and Lagerstrand L, 1999
Respir Med **93**, 79-87
- VII **Growth hormone treatment increases CO₂ response, ventilation and central inspiratory drive in children with Prader-Willi syndrome**
Lindgren AC, Hellström LG, Ritzén EM, Milerad, J, 1999
Eur J Pediatr **158**, 936-940

Abbreviations and words

CNS – central nervous system
CPAP – continuous positive airway pressure
COPD – chronic obstructive pulmonary disease
CPG – central pattern generator
DRG – dorsal respiratory group
ETCO₂ – end tidal partial pressure of CO₂ in the airways
FRC - functional residual capacity (resting lung volume)
P_{0.1} – index of respiratory drive based on mouth occlusion pressure
PCO₂, PO₂ – partial pressures of carbon dioxide and oxygen
PEEP – positive end expiratory pressure
PNS – peripheral nervous system
PRG – pontine respiratory group
PWS – Prader-Willi syndrome
RR – respiratory rate (breathing frequency)
S_pO₂ – blood Hb oxygen saturation assessed by pulse oxymetry
SIDS – sudden infant death syndrome
T_E, T_I – expiratory/inspiratory breathing times
T_I / T_{TOT} – duty time
T_O – occlusion time
T_{TOT} – breath duration
V_T – tidal volume
V_T / T_I – mean inspiratory flow
V̇_I – minute ventilation
VRG – ventral respiratory group

afferent, efferent – carrying toward, carrying away

dorsal, ventral, rostral – toward the back, the front, the beak

respiratory drive – the “output” from the CNS to the respiratory
“pump” muscles

hypo-, hyper – decreased, increased

pressure – 10 cm H₂O ~ 1 vol% ~ 1kPa ~ 7,5 mm Hg

Preface

Life and breathing are intimately linked. This is the thought behind the words for soul or spirit in many languages, and the story of creation of man in the Bible.

In medicine, breathing has to be carefully monitored in a critically ill or injured patient. The strategy to achieve proper breathing is a strategy of survival. This work deals with the control of breathing, and the origin of the breathing effort, which may be called the respiratory drive¹. The attempt is to get a simple measure of this driving force.

The results should be judged as an interdisciplinary work from somebody who was originally trained as an engineer in applied physics, and with a career in the biomedical engineering laboratory. Together with colleagues, I have performed measurements on people, involving aspects of physiology, pharmacology, anesthesiology, pulmonary medicine and pediatrics. It is my hope that this work will contribute to the wholeness of science, and have a meaning in the targeted areas.

The work has been most stimulating, and I would not have missed the experience of being a research student. As major mistakes and failures normally are well obscured in the scientific presentation, I would like to mention the importance of having made them. All the trials that failed, or were not good enough to finish, all the hours working with the wrong hypothesis, and, maybe most frustrating, all the perfect recordings that were lost, due to an ill-functioning computer – “What! Did you annihilate the data!!!?”, as the supervisor loudly roared - yes, I wouldn't have missed that.

¹ Synonyms for drive (noun) are effort, moment, impulse, motive, energy, incentive, pressure, vigor. All are relevant in the context for this study.

Principal aims of the project

- To develop devices and methods for assessment of respiratory drive in man
- To use and evaluate the methods in studies of respiratory control, and in pharmacologically or pathologically altered breathing

Specific aims

Study I: To study the influence on breathing of a simplified technique for breath-by-breath determination of $P_{0.1}$

Study II: To implement a technique for breath-by-breath determination of $P_{0.1}$, using a commercial ventilator. To explore the possibility to impose a mechanical load from the same ventilator

Study III: To implement a method of studying the function of the respiratory centers by repeatedly evoking transient responses to small mechanical stimuli

Study IV: To develop methods to assess respiratory sensitivity to carbon dioxide for the clinical setting, and compare the rebreathing method with a method using brief pulses of carbon dioxide

Study V: To determine the ventilatory effect of ketamine, in combination with alfentanil, using computer-controlled infusions

Study VI: To study the long-term development and patterns of nocturnal hypoxaemia in COPD patients, and the relation to sleep quality, respiratory drive and CO_2 sensitivity

Study VII: To investigate the effect of growth hormone treatment on breathing in PWS patients

Background

Physiology of breathing

The location of a respiratory center in the medulla oblongata was first suggested by Julien Jean LeGallois 1812 (Derenne JP *et al.* '78). Today, there is a considerable knowledge of the organization and function of the regulation of breathing. Still, however, it is far from fully understood (Bianchi *et al.* '95; Onimaru '95; Nattie '99).

The primary aim of respiration is to meet the demands of the metabolism in the body. To that end, respiration functions as a part of the metabolic infrastructure, mainly by providing the body with oxygen and removing carbon dioxide. Other functions of the respiratory apparatus are to participate in the regulation of acid-base balance, the fluid balance and the body temperature. Respiration is also necessary for the ability to speech (phonation). The central controller in the CNS has a remarkable ability to adapt to the many different demands, receiving information from sensors in the body.

Sensors

Any regulatory system may be characterized by three components: sensors, controller and effectors. Information from the various sensors (receptor neurons in PNS and CNS) is processed by the respiratory system's controller (situated in the CNS) to form the output to the effectors (respiratory muscles and lungs).

Important information influencing the respiratory output is collected by the central chemoreceptors. Their existence has been known for more than 70 years. Experiments with artificial cerebrospinal fluid linked them later with neurons on the surface of the ventrolateral medulla oblongata (Schlaefke '81; O'Regan and Majcherczyk '82). The central chemoreceptors are sensitive to local pH and maybe directly to CO₂ concentration (Nattie '01a). They are

thus affected by the PCO_2 of the blood perfusing the brain tissue and the bicarbonate buffer of the cerebrospinal fluid. Because of the relative impermeability of the endothelium of the capillaries and the epithelium of the choroidal plexuses where the cerebrospinal fluid is formed (blood-brain-barrier), the central chemoreceptors are essentially influenced by respiratory acid-base disturbances in the blood, *i.e.* blood PCO_2 , and to a much lesser extent by metabolic acid-base disturbances. This specific sensitivity to blood PCO_2 of the central chemoreceptors is a consequence of the high mobility of the CO_2 molecules, while most ionized molecules like H^+ and HCO_3^- cannot penetrate the blood-brain barrier.

The mechanisms underlying chemosensitivity are still not well understood. Recent research reveal a complex and fascinating neural organization (Horn and Waldrop '98; Nattie '99; Ballantyne and Scheid '01a, b; Nattie '01a, b; Nattie and Prabhakar '01). Chemosensitivity is more widespread than earlier believed. Many sites in medulla, pons and other areas of the brain are involved. The sites vary in their characteristics (sensitivity, specificity, threshold level, neurotransmitter mechanism). For instance, the contribution of a site seems to depend on the state of arousal and sleep, and no group of chemoreceptors accounts for more than a fraction of the total output sensitivity (Nattie '01a). The receptor mechanisms, which involve membrane properties and synaptic transmissions, are probably of several kinds (Bianchi *et al.* '95).

The chemosensitive sites, and their couplings to thermoregulation, nociception and arousal mechanisms in hierarchical and parallel systems, are suggested to have evolved from different functions in mammals, such as air breathing, homeothermy and sleep state (with differentiation between NREM and REM types). This may provide tuned control and stability for breathing in a variety of conditions (Erlichman and Leiter '97; Wilson *et al.* '00; Derby and Steullet '01; Morrell *et al.* '01; Nattie '01a; Remmers *et al.* '01).

The central controller also receives information from the peripheral chemoreceptors. Approximately one third of the

regulation of breathing during normal ventilation is mediated by these receptors (Edelman *et al.* '73; Bellville *et al.* '79), via branches of the 9th and 10th cranial nerves projecting to the dorsal medulla. They are sensitive to blood PO₂, PCO₂ and pH. Some are located in extremely well perfused paraganglia close to the bifurcation of *a. carotis* (carotid bodies). Others, which are less prominent, are found in paraganglia of the aortic arch (aortic bodies).

The carotid and aortic bodies contain different cell types, whose function and interaction have not been fully elucidated, but the overall effect is that these receptors have a unique role for the increase in breathing due to hypoxia.

The hypoxic ventilatory response from the peripheral chemoreceptors has a nonlinear shape. Normally moderate, the response is activated increasingly when PO₂ values falls below 80 mmHg (Weil *et al.* '70). The response to pH is nonlinear in a similar way, making CO₂ the dominant chemical regulator of breathing through both central and peripheral receptors within normal ranges. The location of the peripheral chemoreceptors, close to the arterial blood flow, make them faster than the central chemoreceptors and probably more important for early onset and transient responses (Edelman *et al.* '73; DeGoede *et al.* '85).

The peripheral chemoreceptors are also sensitive to changes in blood pressure (Heistad *et al.* '75) and temperature (Mortola and Frappell '00).

Inputs can influence each other on the peripheral and central level. A well-known example is the effect of PO₂ on the sensitivity to carbon dioxide, and vice versa. For instance, the ventilatory response to CO₂ is potentiated, if the peripheral chemoreceptors are simultaneously stimulated by hypoxia.

Possible sites for additional, hypothetical, chemoreceptors are suggested in *e.g.* the lungs, the muscles and the lower hypothalamus (Horn and Waldrop '98; Solomon '00; Patel and Honore '01).

A fact not explained by chemoregulation is the rapid increase in breathing that occurs during exercise. Especially in the initial phase

of exercise, when the O₂ uptake can rise quickly from a few dl/min to several l/min, it is believed that there is a central coinnervation from motor cortex and hypothalamus, that also influence medullary centers. In addition, there seems to be a neural feedback to the central controller from mechanoreceptors in the muscles and the skeletal joints (proprioceptors) and a potentiation of the carotid bodies from increased [K⁺] (Duffin '94; Eldridge '94; Paterson '97; Ward '00).

In the upper airways and the lungs, there are receptors involved in facilitating and controlling breathing (Sant'Ambrogio *et al.* '95; Akahoshi *et al.* '01). Pressure sensing afferents are particularly numerous in the laryngeal area, a place where it is ideal to detect collapsing forces in the compliant pharyngeal region. To limit the effect of these forces, upper airway dilators are activated and the inspiratory drive reduced. Sensors in the nasal mucosa, the epipharynx, the larynx and trachea, that are sensitive to chemical or mechanical stimulation, are associated with reflexes such as apnea, sneezing, sniffing and coughing.

The lung tissue contains many types of receptors transmitting information through branches of the vagus nerve. Pulmonary stretch receptors are found in the airway walls and the lung parenchyma. They are activated by lung distention and give rise to the classic Hering-Breuer reflex, associated with the inspiratory off-switch and prolongation of expiration. The irritant receptors in the airway epithelium are suggested to elicit expiratory reflexes to touch and chemicals, and are particularly sensitive to histamine. The J receptors in the alveolar walls (juxtapulmonary capillary receptors) are also associated with nociception, but they are maybe primarily sensitive to mechanical events, such as lung congestion and edema.

In awake man, sensory feedback other than of chemoregulatory origin may well be the dominant input to the central controller. If there is an absence of chemosensory stimulus, this input can function as a substitute for the metabolic drive (Shea '97; Horn and Waldrop '98; Nattie '99). For instance, the influence on breathing of

excitement, panic or pain is obvious to anyone. This suprapontine stimulation involves reflexes related to regulation of wakefulness, arousal, locomotion, and sensations of noxious and emotional origin.

Several respiratory-related functions are associated with the hypothalamus: 1) An increase or a slight decrease in body temperature enhance ventilation beyond what is related to CO₂ production (Boden *et al.* '00a, b). Deep hypothermia inhibits breathing (Maskrey '95). 2) Emotions, *e.g.* fear, anxiety and rage are already mentioned. 3) The production of releasing hormones, which influence the levels of thyroid hormones and progesterone, both stimulating ventilation (Wolfe *et al.* '98; Tatsumi '99; Frankovich and Lebrun '00). 4) An alternative site for chemosensitivity, also mentioned above.

Sensory inputs that interact with ventilation but are not primarily involved in the control of respiration may be termed unspecific drives: Hot and cold stimuli to the skin influence ventilation. Cold water immersion provokes the inspiratory “gasp” reflex (Mekjavic *et al.* '87; Burke and Mekjavic '91). Cooling of the airways decreases ventilation (Giesbrecht '95; Sant'Ambrogio *et al.* '95). The diving response, elicited when water touches the face, has an inhibitory influence on respiration and increases breath-holding (Mukhtar and Patrick '86; Gooden '94). Pain can be a powerful stimulus. A rise in arterial blood pressure depresses ventilation and CO₂ sensitivity (Grunstein *et al.* '75; Heistad *et al.* '75).

All the information from the numerous, identified or yet to be identified, sensors of the system is managed by the respiratory controller.

Respiratory centers

It has long been recognized that the respiratory controller in the CNS is composed of two functionally and anatomically separate parts: the voluntary respiration, controlled by the cortex, and the autonomous respiration, governed by structures within the brainstem (Berger *et al.* '77). The volitional control involves the forebrain and implies that the autonomous respiration is modulated

through descending neural pathways, similarly to the control of posture and locomotion. This constitutes an additional drive for breathing, by-passing and confusing the metabolic mechanisms (von Euler '77), passing down the lateral spinal columns in the corticospinal tracts. The autonomous pathways from the brainstem travel in the ventral and ventro-lateral columns as the bulbospinal tracts.

The organization, function and localization of the autonomous respiratory controller has been the object for numerous studies, but are still not well understood. Current knowledge is mainly based on animal experiments, *e.g.* cat and rat. One abandoned idea, which was based on classical transections of the brainstem, assumed that specific respiratory functions resided within circumscribed structures (*i.e.* the pneumotaxic and the apneustic center in the pons, and the medullary centers, subdivided in the inspiratory and expiratory half-centers). The model has been modified by introducing the now current term “central pattern generator”, CPG (Bianchi *et al.* '95). The respiratory CPG model is characterized by an intricate network of neuronal populations, generating the respiratory activity in complicated coordination.

The synaptic network mechanism assumes reciprocal inhibitory connections between the neurons and influence on the intrinsic membrane properties. In this model, respiration is a sequential motor behavior, activating in steps at least six different neuronal populations found in the CPG: Pre I, Early I, I aug, Late I, Post I and E aug neurons; their names indicating their roles. Each step is conditioned by the previous one and initiates the next, thus generating the three phases in respiratory rhythm: inspiration, post-inspiration (E1) and expiration (E2) (Richter *et al.* '92; Bellingham '98).

Three major bilateral clusters of respiratory neurons are generally recognized: the pontine, the dorsal and the ventral respiratory groups (PRG, DRG, VRG), but several other clusters are recognized (Bianchi *et al.* '95; Nattie '99). The PRG lies in the dorsal lateral pons. These neurons seem to stabilize the respiratory

pattern, slow the rhythm and influence the timing of the respiratory phases, but they are not essential for the respiratory rhythm generation *per se*.

The DRG lies in the region of the nucleus of the solitary tract (NST) in the dorsal medulla. It receives ascending afferents via the 9th and 10th cranial nerves and the spinal cords. The majority of the DRG neurons have inspiratory-modulated discharge patterns and efferent connections to respiratory premotor neurons and motoneurons.

The VRG is a long column of cells in the region of nucleus ambiguus but extending the full length of the ventrolateral medulla. In the VRG, there are many kinds of respiratory neurons. Bulbospinal expiratory and inspiratory neurons send efferents to premotor- and motoneurons of the respiratory muscles. Propriobulbar neurons coordinate the activity of other medullary CPG neurons. The intermediate part of VRG is believed to be important in the respiratory CPG organization. One adjacent area, rostral to the VRG, termed the pre-Bötzinger complex (PBC), has been hypothesized to be the source of pre-inspiratory bursting, *i.e.* having a pacemaker function, or functioning as a fall-back or auto-resuscitation and center for fetal breathing.

The existence of an inspiratory rhythm-generating kernel of less than 600 neurons in the PBC has gained increased attraction recently (Rekling and Feldman '98; Koshiya and Smith '99; Johnson *et al.* '01; Thoby-Brisson and Ramirez '01). The pacemaker paradigm now seems to be more accepted (Gray *et al.* '01), but there are still major confusing observations in relation the pattern-generator network, and a synthesis of the two models is expected (Lindsey '01; McCrimmon *et al.* '01).

The afferent activity from different sensors in the body is received by the CPG, and then processed and modified in its outcome. One input can influence the outcome of another, *e.g.* at sleep, when the wakefulness stimulus is absent, the response to CO₂ is reduced (Nattie '99). The differentiation and interaction between neuronal groups in the brain are attracting great interest, as new methods

are evolving to stimulate or neutralize neuronal groups (Nattie '01a, b).

Parts of the respiratory neuronal network and related muscles also serve in other neuronal circuits with non-respiratory functions. These functions include postural control, phonation, protective reflexes of the upper airways, *e.g.* cough and sneeze, and expulsive maneuvers, *e.g.* vomiting, defecation, micturition and parturition (Iscoe '98). Gasping may represent the output of a simple but rugged pattern generator that functions as a backup system until the control system for eupnoea is developed (St John '90, '96). A picture is emerging of many different CPGs in the brain, some physically very close to or part of the respiratory CPG, and, that these CPGs are able to coordinate their activities.

The suprapontine control of respiration is not well investigated. With new imaging techniques (PET and fMRI) networks can be visualized; it can for instance be demonstrated that structures involved in motor functions, such as the motor cortex and basal ganglia, are activated during volitional and increased breathing. It has been shown that hypothalamic and midbrain areas have various respiratory connections, and they seem to be active in more advanced respiratory control during several conditions, such as locomotion, the defense reaction (panic), homeostasis (Horn and Waldrop '98) and disease (Harper *et al.* '00b).

The separation between voluntary and automatic respiratory control is sometimes evident after a damage in the CNS. Voluntary breathing may not overrule the chemoregulation. Or the opposite, the automatic breathing is lost, and a person suffering from this “Ondine’s curse” stops breathing at sleep (Strauser *et al.* '99).

Respiratory output

The effectors of the respiratory system include the “pump” muscles, the muscles controlling airway dimensions and other muscles that are activated rhythmically when breathing.

The respiratory pump muscles cause lung volume changes. They have neuronal pathways from bulbospinal premotor neurons

situated in the medulla, projecting to motoneurons in the spinal column. The major pump muscle, the diaphragm, is innervated from phrenic motoneurons at the costal segments C₃-C₆. The intercostal muscles are innervated from motoneurons at T₁-L₃, and the abdominal muscles at T₄-L₃ (Bianchi *et al.* '95).

Regulation of the airway dimensions are performed by: the alae nasi, the constrictors and dilators of the pharynx, the tongue protrusion, the abductors of larynx and the smooth muscles in the bronchi; they are innervated via branches of the 7th, 10th and 12th cranial nerves from motoneurons in the brainstem.

Upper airway patency is important, to protect from airway collapse at inspiration. It is maintained by tensor muscles in the nasolaryngeal passage and soft palate, innervated from the 5th and 7th cranial nerve.

The effectors are coordinated by the respiratory CPG in normal breathing. But they are also recruited, exclusively or in combination, by other CPGs in specialized activities, such as coughing, sneezing, singing, locomotion, vomiting, which have been discussed above.

A simple integrator-based theoretical model can help understand how the respiratory output is formed (Rhoades and Tanner '95). The integrator is presumed to reside within the medullary network. It is affected by all the sources that contribute to respiratory drive, as it increasingly activates the inspiratory premotor neurons of the DRG-VRG complex. Inspiration ends by an off-switch, which determines the depth of breathing, from growing inhibitory activity, and the integrator is reset.

After the termination of inspiration, some activity of the inspiratory muscles resumes in a receding manner. This is the post-inspiration phase, when the expiratory flow is reduced in a controlled manner from what would else occur by passive recoil of the pulmonary system. Not until the second phase of expiration, the expiratory muscles may be activated. The duration of expiration is determined by the inhibitory intensity on the inspiratory neurons, which declines until the switch to inspiration is initiated again.

Another model of thought is that of multiple control strategies for respiration. We can describe several ways to meet similar demands, even if the integration of these strategies is not understood. In exercise, for example, the initial rapid ventilatory increase is believed to be induced by the activity in the motor cortex and the limbs. This is believed to be a feedforward strategy, which is not adjusted by its outcome. Instead, the response seems to be finely tuned to the set point by the slower feedback strategy, which controls blood gas levels (Duffin '94; Eldridge '94; Forster and Pan '94; Paterson '97; Ward '00). A third strategy is to minimize energy expenditure by regulating the breathing frequency to tidal volume relation, which depends on *e.g.* body mass and pulmonary stiffness.

The final result of the inspiratory activity is determined by mechanical and geometrical factors of the lungs and thorax, and the capability to coordinate the effectors. The ability to move gases of various viscosity in the airways (resistance), and the elastic properties of the lungs and the chest wall (compliance) are essential qualities and can alter rapidly in disease. The lung volume *per se* is a determinant. The nonlinear relationship between the generated force and length of a muscle must also be considered; this means that the diaphragm, with its dome-shaped configuration, is more forceful at the start than at the end of an inspiration. Similarly, the force-velocity relationship implies that the power output and efficiency of the respiratory muscles depends on the speed of contraction. Ultimately, the share and coordination between different respiratory muscles will influence the relation between respiratory drive and performance.

Assessment of inspiratory activity

Drive and timing

A simplified concept of respiratory drive is to consider it as the integrated “output” signal from the CNS to the respiratory “pump” muscles. This signal is actually a complex of impulses from different

neuronal nuclei, following different neuronal pathways. The respiratory drive can further be described functionally: a voluntary drive, a behavioral drive, a hypercapnic drive or a hypoxic drive, depending on the cause of the signal.

The effector muscles, primarily the diaphragm, intercostals and abdominals, function as a pressure generator, producing the volume changes that constitute breathing. Thus, a pattern of neuronal activity is transformed and reflected into one resulting quantity: the pressure of the airways. The airway pressure, and the volumes and flows generated by it, are also results of other factors not necessarily determined by the respiratory CPG, such as lung anatomy, elastic properties of the lungs and the thorax cavity and the flow resistance of the airways.

Because of the complex character of the CPG there is no simple direct estimate of the respiratory drive. Measurements are bound to be either selective or indirect (see below).

The most easily assessed measure of breathing is the respiratory rate (RR) or frequency, which is the reciprocal of breath duration (T_{TOT}). It reflects the timing of respiration (rhythm), as do the time of inspiration and expiration (T_I and T_E). Together with the amplitude of a breath (the tidal volume, V_T), the final output of the respiratory apparatus is traditionally formed from timing as $\dot{V} = V_T * RR$, often called minute ventilation.

Clark and von Euler ('72) were the pioneers to analyze the depth and timing of breathing, formulating relations between a centrally generated drive, the timing and the tidal volume. The central controller was divided in two parts: an activity generator and a timer. To express this understanding more appropriately, the standard formula was rearranged into $\dot{V} = 60 * (V_T/T_I) * (T_I/T_{TOT})$ (Milic-Emili and Grunstein '76), where drive (V_T/T_I , the mean inspiratory flow) and timing (T_I/T_{TOT} , the so called duty time) are reflected separately.

Thus, mean inspiratory flow can be said to reflect the respiratory drive more specifically than ventilation in general does.

Some other possible methods to assess the central inspiratory activity include assessment of the respiratory mechanical work (Cherniack and Snidal '56; Milic-Emili and Tyler '63), the oxygen cost of breathing (Cherniack '59), the speed of contraction of the respiratory muscles (Pengelly *et al.* '71), diaphragm electromyography (Lourenco and Miranda '68) and the phrenic nerve electroneurography (Eldridge '75), the latter method used only in animal studies. They all have technical and principal limitations and have not been widely used in humans.

The methods can be divided into those that measure selective parts of the central command signal (ENG, EMG) and those that, indirectly, represent the net sum of actions resulting from the respiratory CPG (flow, pressure, work).

Occlusion pressure and $P_{0.1}$

Another approach to the problem of finding a measure of respiratory drive, which is not new but became carefully investigated in the 1970s, is airway occlusion pressure. Occlusion pressure here refers to a pressure measurement in the airway of a spontaneously breathing subject, after the airways unexpectedly have been closed at the end of an expiration. Studying breathing in anesthetized cats, Grunstein *et al.* ('73) occluded the airways at functional residual capacity (FRC, the resting volume at end expiration). Their conclusion was that the maximal amplitude of tracheal pressure generated in the following inspiratory effort is a measure of the “output of the respiratory centers”. They also noted the “isometric” character of this type of measurement and the “absence of any volume-related vagal modulation” of the respiratory output. Other investigators further observed that during the airway occlusion maneuver, the internal airway impedance was “infinite”.

Thus, the isometric or isovolumetric measurement at FRC, implicated limited or absent influence from 1) the airway resistance (no flow), 2) the compliance of the lungs and thorax (relaxed lungs and no volume change except a small increase due to decompression of the air in the lungs) and 3) the respiratory muscles' force-length

and force-velocity relation (the muscles expected to shorten much less at occlusion). It was concluded that many of the mechanical factors involved in the transformation of respiratory motor neuron discharge into ventilation were eliminated with this method (Milic-Emili *et al.* '75).

The technique was immediately appreciated because many diseases and medical procedures affect these mechanical factors of the lungs, and occlusion pressure might be a tool that could help distinguish between “can’t breathe” (pump dysfunction) and “won’t breathe” (central command dysfunction) during hypoventilation.

For conscious, non-anesthetized subjects or animals, though, the peak pressure of one occluded whole breath cycle was not a good measure, because it cannot occur without generating reflexes in response to the hindrance. The subject might fight against it or cut short the inspiratory effort. But it was observed that the shape of the pressure-time curve in anesthetized cats “remains virtually invariant, implying that the pressure at any fixed time after the onset of inspiration is as valid a measure of the respiratory centre output as is the peak pressure” (Whitelaw and Milic-Emili '73). This led them to suggest that in conscious man the occlusion pressure at the beginning of the respiratory effort, “before cortical reflex effects could occur, would be a useful measure of respiratory centre output.” The new idea of brief occlusion measurement was later further elaborated and described in detail in a very influential paper (Whitelaw *et al.* '75), where they also launched the concept of $P_{0.1}$. They found that distortions resulting from conscious and unconscious responses to occlusion had a minimum latency of 0.15 s, and therefore they suggested that the pressure drop generated 0.1 s after the onset of inspiration ($P_{0.1}$) would be a useful index of the output of the respiratory centers. It was reproducible in each subject at different levels of ventilation (*i.e.* different airway PCO_2 due to rebreathing), and they postulated that for an isometric contraction at fixed lung volume and configuration,

$$\text{Occlusion pressure} = K \times \text{Neuronal discharge}$$

where K is an expression of the effectiveness of the contraction of the respiratory muscles and depends on several factors that may differ between individuals. And though there were critical aspects of the $P_{0.1}$ technique, related to change in lung volume and configuration during CO_2 rebreathing, and the relation between former and later parts of inspiration, this was obviously a quick, simple and non-invasive technique for both physiological and clinical investigation. In comparisons to measured electrical activity in the phrenic nerve and the diaphragm, it also appeared reasonable (Evanich *et al.* '76; Lopata *et al.* '76; Lopata *et al.* '77a; Lopata *et al.* '78; Pimmel and Eldridge '79).

A slightly different approach to determine respiratory drive was presented by Burki *et al.* ('77), referring to an earlier paper (Matthews and Howell '75). They measured maximal rate of rise of the mouth pressure at occlusion, dP/dt max. They found that dP/dt max occurred in average 0.12 s after occlusion and had a close correlation to $P_{0.1}$ at both hypercapnic and hypoxic challenges in normal subjects. This approach has not become popular but has an interesting relationship to the algorithm used in our study I.

$P_{0.1}$ has become a de facto standard procedure to estimate respiratory drive. Numerous studies in respiratory physiology, pulmonary medicine, anesthesiology, pharmacology, pediatrics etc have been published, where the $P_{0.1}$ technique has been an essential tool in the analysis of the respiratory function.

A critical view on the occlusion pressure technique

With accumulated experience of occlusion pressure measurements, came a more cautious view on its qualities. In a review (Whitelaw and Derenne '93) it was stated that some of the original postulates were not correct or approximations that have to be carefully controlled in any specific study. To begin, the concept of “output” of the respiratory controller is controversial, and its definition tends to be “operational”, depending on what is “measurable”. The achievement of the measurement of occlusion pressure is, that it correlates reliably with other measures that can

be defined as outputs of the respiratory controller, and, that it in combination with other measurements can give a more complete information on the respiratory system's function. But if basic assumptions were to be accepted in an uncritical way, simplistic conclusions could result from the interpretation of the measurements, according to the authors.

One example is when impedance can influence the occlusion pressure measurement indirectly in the COPD patient, who moreover has an end expiratory volume above normal to compensate for the obstruction, whereby the force-length relation of the respiratory muscles is different from normal. Other diseases or situations may also change the lung volume, the chest wall configuration or the contribution of various respiratory muscles in the breathing effort from the assumed normal. Furthermore, experiments in anesthetized animals have shown that the diaphragm shortening is substantial also during occluded inspiration, which is contrary to the original assumptions.

As for the brief occlusions ($P_{0.1}$), which have been most widely used, much of the criticism concerns the shape of the occlusion pressure wave. The undistorted or unconscious subject seem to generate the same waveform following stereotyped muscle sequences in all inspirations, in a wide ventilatory range. But a change in the respiratory CPG, a spinal reflex or a muscle could influence only a part of the inspiration, and in that case the $P_{0.1}$ may not represent the whole inspiration or the CPG output in the same way as before. One example is during positive pressure support when the occlusion pressure wave becomes more convex downwards, having a decreasing gradient to the time axis. The effect of this shape is as if the respiratory drive gradually decreases during inspiration in response to the support, but this is not reflected in the relatively high $P_{0.1}$, that is received from the initial part of inspiration. A change of shape seems to appear in connection with mechanical loading.

Brief occlusions might also be influenced by the not yet relaxed expiratory muscles at the beginning of inspiration. The original

thought was that these muscles would be inactive and at rest during the expiratory pause, but at forced breathing this is not always true. The problem is to some extent semantic (what should define the pressure-generating output); this complication doesn't seem to change the measurements *per se* during rebreathing.

Another complication is the assumption that mouth pressure represents the intra-thoracic pressure generated by the respiratory muscles. This is normally true especially when there is an expiratory pause. But in the case of a large respiratory impedance or an increased ventilation, there might be phase shifts between pressure and flow. If time constants are long enough, there is still an internal airway flow at the onset of inspiration, and mouth pressure might lag behind the pleural pressure wave. If the shape of the pressure wave is nonlinear, this would influence $P_{0.1}$, which would be measured from another part of the occlusion pressure curve. Because this is a consequence of the resistance occurring at end expiration, it would be important in the obstructive lung patient. Experiments in COPD patients have not clarified the importance of a delayed onset of measurement in esophageal, tracheal and mouth pressure waves (Murciano *et al.* '82; Elliott *et al.* '93). On the other hand, tracheal intubation in these patients yields higher $P_{0.1}$ values, indicating an influence of upper airway resistance and compliance also on brief occlusions.

Still, in spite of the many arguments as to what is actually measured with occlusion pressure, it remains a widely used technique as it is the only convenient, noninvasive measure of output that can be used to assess respiratory motor activity across conditions where respiratory resistance or elastance is changed (Whitelaw and Derenne '93).

Put into practice, $P_{0.1}$ adds another dimension to the Milic-Emili-Grunstein formula above for ventilatory drive and timing: The mechanical impedance of the respiratory system is reflected in the ratio between $P_{0.1}$ and \dot{V}_T / T_I , in accordance with Ohm's law. $P_{0.1}$ is the "voltage" analogue and the mean inspiratory flow is the "current".

Instrumentation

Customarily, research groups have designed their own equipment to assess breathing and respiratory drive. Usually, inspiratory and expiratory lines are separated by means of two one-way valves in combination (a two-way non-rebreathing valve). Subjects breathe through a mouth piece. Occlusions are provided, either by means of a bore stopcock, an inflating balloon inside lumen of the inspired line, or an electronically operated, *e.g.* a solenoid, shutter. The shutter is activated manually at expiration. This set-up guarantees that inspiratory occlusion starts at zero air flow. The maneuver must of course be silent and hidden from the subject, and can not be repeated too often. Pressure and CO₂ concentration is recorded at the mouth piece. Flows can be measured in many ways, for instance by means of a spirometer or a pneumotachograph. The set-up is often combined with a rebreathing bag to provoke increased breathing activity during experiments. In the original works, the signals were fed to a fast chart recorder or a storage oscilloscope, and variables such as P_{0.1} were read by eye from the tracing.

The many measurements made studies cumbersome, and soon automatic devices appeared. Electronic circuits made the re-opening of the valve quicker and could also help determine P_{0.1} automatically (Linnarsson and Hesser '78; Jordan '81; Delavault et al. '84). This meant shorter occlusions, that interfered less with the breathing pattern. The automated calculation of P_{0.1} had a high precision and no observer bias. Computers were soon included in the instrumentation.

A further natural development was breath-by-breath measurement, *i.e.* determination of P_{0.1} on every single breath (Altose *et al.* '75, '79; Ward *et al.* '81; Andriano *et al.* '83; Lind *et al.* '84; Pourriat *et al.* '94; study I) . This was possible as occlusions became even shorter. The argument was to increase the number of data and compensate for a high variability. A problem was whether the measurements would influence the quantity being measured (see study I).

Still, highly automated systems have been in a minority among the numerous studies published incorporating $P_{0.1}$ measurement. Traditional laboratory components as proposed by the early workers have been frequent. Some investigators have used one of the few instruments that are commercially available for the purpose, such as the Inspiratory Occlusion Pressure Valve Setup (Hans Rudolph, Inc., Kansas City, MS) and the CP-100 Pulmonary Monitor (Bicore Monitoring Systems, Inc., Irvine, CA; Petros *et al.* '93).

Another attractive option appeared when a standard mechanical ventilator could be used as a measuring device (Hellström *et al.* '88; Brenner *et al.* '90; Kuhlen *et al.* '95; Kuhlen *et al.* '96; study II). The technique would then be clinically available for routine analysis at bed-side. Today, some manufacturers offer $P_{0.1}$ measurement as an integrated function of the ventilator (Hamilton Medical AG, Rhäzüns, Switzerland and Dräger, Lübeck, Germany). Single measurements are performed through manual intervention. The obvious advantage with this facility, except the access to a standard measuring device instead of laboratory equipment, is the possibility of respiratory output estimates in connection with clinical patient care; selecting appropriate support mode, weaning and patient monitoring. The problem could be that measurements are qualitatively inferior in comparison to a laboratory system, due to a presumably poorer mechanical performance of the ventilator (see study II).

Provocation of ventilatory adjustments

Normal and abnormal regulation

Normal breathing at rest is characterized by a considerable variability, both intra- and inter-individual (Lenfant '67; Hlastala *et al.* '73; Burki *et al.* '77; van den Aardweg and Karemaker '91); study I). This is hardly surprising considering the complexity of the regulatory system and its ability to respond to all kinds of sensory information. When there is an increased demand, *e.g.* from exercise,

the system has a great potential to adapt rapidly within a large ventilatory range. In fact, the strategy of an individual respiratory CPG to respond to and compensate for changing conditions is also a respiratory variable.

For the clinician, it is sometimes important to know the status of the respiratory controller, to judge the function of the respiratory system and to select the correct strategy of treatment. Aberrations can be caused by injuries, disease and environmental factors. Heredity can be important as there is a considerable variation among individuals. Some differences between racial groups are reported (Beral and Read '71; Cruz and Zeballos '75), while influence of sex and age are difficult to discern (Scott and Burki '90).

Control theory

Any system which contains feedback mechanisms is subject to an oscillatory behavior. An analysis of the natural fluctuation of respiratory variables reveals a superimposition of cyclic variations of several frequencies (Lenfant '67). The multiple feedback loops and the interaction between respiratory variables affects this variability in a complex way (Hlastala *et al.* '73; Patil *et al.* '90).

According to control systems theory, a “deterministic disturbance”, *i.e.* an externally introduced input, can be applied in order to investigate the function of a regulator. The disturbance can be applied as a step change, a ramp or a brief pulse, whatever might appear most appropriate depending on circumstances (Brogan '90). Such artificial challenges to breathing are often performed in studies of the respiratory system.

Occlusion pressures at rest are typically small and variable, and reflect the irregularity of tidal volume. It is therefore natural that many investigators of breathing choose some form of forced breathing, such as inhalation of CO₂, hypoxia or exercise, in their studies (Milic-Emili *et al.* '77).

Interference from measurement

It is well known that respiratory variables are influenced by the measuring process. In theory, all measurements interfere, as they draw energy from the process they measure. Influence of the measuring equipment, *e.g.* added impedance or compliance, may cause confusion in the interpretation of respiratory monitoring (Elliot and Topulos '90). Experiments in the physiology laboratory or clinic are influenced in other ways too. Most respiratory experiments are performed with the subject breathing through a mouthpiece and wearing a noseclip. The effect of shifting the breathing route from nasal to oral (noseclip) normally results in decreased respiratory rate, by prolongation of the expiratory time, and an increase in tidal volume and respiratory drive (Gilbert *et al.* '72; Douglas *et al.* '83; Weissman *et al.* '84; Maxwell *et al.* '85). The use of a mouthpiece can increase ventilation, and this effect can disappear if the mouthpiece is narrow (Weissman *et al.* '84).

It is believed that the effect of shifting breathing route can be explained by altered receptor activity in the upper airways and the low resistance of the oral airway. If there is an added external dead space from the respiratory apparatus, it can also influence the breathing pattern. Breathing through a standard facemask seems to interfere less with the breathing pattern (Maxwell *et al.* '85; Western and Patrick '88). The oral breathing route seems to be less suitable for compensating inspiratory flow-resistive loads (Nishino and Kochi '94). As for occlusion pressures, there is no difference (Scott and Piquette '93).

The behavior of the subject can be crucial. Many measurements on patients at rest suffer from an increased ventilatory drive and hyperventilation. The subject should cooperate, and in the same time be relaxed and diverted from thinking on his or her breathing. Focusing on breathing increases tidal volume and decreases frequency (Western and Patrick '88). Relaxation feedback, on the other hand, when the subject is taught to relax muscles and can follow the results, reduces the response to hypercapnia, in

ventilation, respiratory drive and respiratory rate (Holliday and Veremakis '99).

The posture of the subject must also be considered. The end-expiratory lung volume tends to decrease during CO₂ rebreathing in a sitting position. This is less so in a more supine posture, when FRC is smaller to begin with. This is advantageous for occlusion pressure measurement (volume dependent) (Milic-Emili *et al.* '75). It also seems that the inter-individual variability in the hypercapnic response is less in the supine position (Lederer *et al.* '77). A semi-recumbent position is often used for practical reasons. Posture does not seem to influence the ventilatory response to CO₂ (Rigg *et al.* '74).

Chemical loading

The term “chemical” in this context can be misunderstood. Even if the chemoreceptors of the respiratory system are sensitive to different stimuli, the term here refers to stimulation by changing the inspired concentrations of CO₂ and O₂.

Stimulation with CO₂ is probably the most common method to study the regulation of respiration. The rebreathing technique, originally proposed by Haldane and Smith 1892, utilizes the intrinsic production of CO₂ from the subjects own metabolism by connecting the subject to a rebreathing system. In total rebreathing, the PCO₂ in the airways will rise progressively in a ramp-like fashion, inducing an increasing ventilatory response, which is more or less linear as a function of PCO₂. The CO₂ sensitivity is measured as the gradient of the response parameter (ventilation, respiratory drive etc) as a function of PCO₂ ($\Delta R/\Delta PCO_2$). A standard procedure (Read '67; Read and Leigh '67) uses a rebreathing bag of approximately the same size as the lungs, that is prefilled with a gas mixture where the initial PCO₂ is close to the PCO₂ of mixed venous blood. The bulk of the mixture is O₂ to eliminate hypoxic stimulation. The purpose is to establish a rapid (< 30 s) equilibrium between end tidal, mixed venous blood and arterial blood PCO₂, that closely reflects the conditions at the central chemoreceptors. This

test is a very robust provocation of respiratory control, which, if continued for 4 min as suggested, brings the subject to an extremely hypercapnic situation, from which it takes time to recover and return to the control level.

An alternative to rebreathing is normally to switch to continuous inhalation of a gas mixture with a fixed concentration of CO₂, such as 2 or 4 %, in a two-way breathing valve set-up. This corresponds to a step-wise introduced stimuli and has been extensively used. The ventilatory response ($\Delta \dot{V}/\Delta P_{CO_2}$) can be more moderate, making the test more tolerable for a normal subject. A disadvantage is the relatively slow dynamic response of chemoreceptivity, *i.e.* the time to reach steady-state level, 10-20 min, with time constants depending on CO₂ concentration, the measured respiratory variable and whether it is an *on-* or *off-*transient (Reynolds *et al.* '72; Gelfand and Lambertsen '73).

A “true” step stimuli to the central controller could be achieved only by enforcing the end tidal CO₂ concentration to a step waveform, through an inspired CO₂ wave which has an impulse-like on-transient, and with end tidal O₂ held constant (Swanson and Bellville '75; DeGoede *et al.* '85). Steady-state in ventilation is reached within 5 min, but this “dynamic end-tidal forcing” technique requires complex instrumentation.

In another method, CO₂ is injected at a constant flow. This makes stimulation independent of ventilation, and transients becomes shorter (Fenn and Craig '63; Jacobi *et al.* '87).

Some investigators have used a “pulse stimulus” approach, *i.e.* subjects are exposed to short (30 s) periods of CO₂ inhalation, occurring repetitively (Jacobi *et al.* '89a and Study IV). The stimulus is thus of limited effect and the ventilatory response has a transient character. The response can be measured as the peak or the integral change in relation to the corresponding PCO₂ stimulus. For a given CO₂ concentration, the response is very small in comparison with the previously described methods. The advantage is that interference with the subject is hardly noticed, and the effect can be integrated by summing results of consecutive pulses of CO₂.

As with other respiratory characters, there is a considerable intra- and inter-variability in CO₂ sensitivity measurements, favoring statistical methods in analyzing results (Strachova and Plum '73; Goodman and Black '85; Goodman and Curnow '85).

The hypoxic ventilatory response is normally much faster than the hypercapnic one, since it is mediated by the peripheral chemoreceptors only, and since the O₂ stores of the body are much smaller than the CO₂ stores. It is more difficult to measure the hypoxic response, as a hypoxic stimulation normally is confused by hypocapnic and alcalotic inhibition when CO₂ is washed out. To neutralize the effect of PCO₂ reduction, the end tidal PCO₂ can be regulated by adding pure CO₂ to the inspired air (isocapnic hypoxia). The sensitivity to O₂ can then be measured in a steady-state manner, breathing from an inspired hypoxic gas mixture, for instance diluting air with nitrogen (Weil *et al.* '70). The hypoxic response can also be measured in a rebreathing test that is similar to CO₂ rebreathing (Kronenberg *et al.* '72; Rebuck and Campbell '74). The subject reduces airway PO₂ by consuming O₂ from the rebreathing bag. PCO₂ is held constant by a variable flow “scrubbing” circuit in the system containing a CO₂ absorber. The inspiratory activity (occlusion pressures) in response to flow resistive loading can be studied in combination (Kelsen *et al.* '76).

A simple test of the peripheral chemoreceptor tonic activity is a “dejours” hyperoxic test (Dejours *et al.* '58). The effect of a sudden switch to breathing pure O₂, which will off-load the oxygen drive and decrease ventilation, is studied.

Mechanical loading

The respiratory response to a mechanical challenge is of great importance for appropriate ventilation. This type of challenge is not only a naturally occurring phenomenon, that the central controller has to cope with to avoid obstructions and keep the airways open. It is also an essential problem in several diseases. The challenge can furthermore be elicited from the respiratory equipment connected to a patient by changing pressure or impedance conditions.

Mechanical loads include elastic (compliance), resistive (flow resistance), pressure and threshold (opening pressure) loads. Whether the effect is during the inspiratory or expiratory breathing phase is of course crucial.

Mechanical loads are primarily mediated to the central controller via peripheral pressure sensor endings in the upper airways (Sant'Ambrogio *et al.* '95). Other intrinsic factors, such as pulmonary receptors and chest wall proprioceptors, also give afferent information on impedance conditions. The dynamic response is much faster than for loads that are mediated by the central and peripheral chemoreceptors. Adaptation to a change in mechanical loading can be accomplished within a few breaths (Campbell *et al.* '61; Altose *et al.* '75, '79) and mechanoreceptor reflexes are active on a within-breath basis (Akahoshi *et al.* '01; Malhotra *et al.* '02).

Inspiratory resistive and negative pressure loads augment the respiratory drive but depress the ventilatory response to chemical stimulation (Kryger *et al.* '75; Altose *et al.* '76; Lopata *et al.* '77b; Tan and Simmons '81; Im Hof *et al.* '86; Poon '89). Inspiratory assistance (negative resistance) and pressure support has approximately the reverse effect, but it seems to be more difficult for the central controller to compensate for this support (Poon *et al.* '87; Gallagher *et al.* '89; study II-III).

Medical treatment and breathing

Clinical care, ventilator treatment and weaning

The need for and the possibilities to monitor various parameters in medical care have accelerated in the last decades. This is also the case for respiration and the assessment of respiratory drive (Tobin '88; Macnaughton '97; De Backer WA '98). The interest for advanced monitoring of respiratory activity might be found in the operation room, the intensive care department, the pulmonary medicine clinic, the neonatal department and other related areas.

Modern intensive care ventilators are sophisticated instruments. If a ventilator's interference with pulmonary mechanics earlier has been associated with added dead-space and breathing resistance, there is now a possibility to add or subtract loads according to a strategy of treatment, aiming at a reduced ventilatory assistance and maintained and augmented spontaneous breathing (Hachenberg '96; Rathgeber '97).

Furthermore, measuring and monitoring capabilities during ventilator treatment have increased, making assessment of the patient's pulmonary function possible (Macnaughton '97). In this context, occlusion pressure should be seen as one parameter of interest. An adequate $P_{0.1}$ has often been suggested as a predictor for successful weaning from ventilation, sometimes in combination with other parameters (Herrera *et al.* '85; Montgomery *et al.* '87; Sassoon *et al.* '87; Soma *et al.* '88; Conti *et al.* '92; Gandia and Blanco '92; Sassoon and Mahutte '93; Nava *et al.* '94; Capdevila *et al.* '95; Mergoni *et al.* '96; Hilbert *et al.* '98; Vallverdu *et al.* '98). Essentially, a high $P_{0.1}$ value indicates a labored pulmonary system and an increased risk of subsequent weaning failure.

$P_{0.1}$ is also suggested as a useful parameter to help in setting the appropriate individual level of pressure support ventilation in patients with acute respiratory failure (Perrigault *et al.* '99). It has been proposed that $P_{0.1}$ values be maintained below 3,5 cm H₂O, corresponding to a work of breathing less than 0,75 J/l, for optimal ventilatory assistance (Marini *et al.* '86; Alberti *et al.* '95). Other combinations of ventilator modes has been suggested to obtain $P_{0.1}$ values close to normal (Appendini *et al.* '99). The $P_{0.1}$ parameter may also help assess the effects of PEEP ventilation and "titrate" a correct level in COLD patients with an intrinsic PEEP (Mancebo *et al.* '00).

Pharmacology and neurotransmission

Numerous drugs affect respiration (Hedner '83). Their involvement in the respiratory CPG is extremely complicated and only partly understood. The following is mainly based on Bianchi

('95). Voltage ion dependent channels, as well as ligand operated and G protein mediated receptor systems are involved. Substances such as GABA, glycine, ACh (via nicotinic receptors) and glutamate are likely involved in the fast neurotransmissions in the respiratory CPG. Substances such as ACh (via muscarinic receptors), serotonin, substance P and somatostatin modulate respiratory activity through their slower activation of G proteins, and are neuromodulators.

Some examples: Muscarinic receptors are thought to be involved in chemosensitivity. Dopamine acts on the carotid bodies. The well-known depressant effect of opioids can be a result of both altered drive and timing (Drummond '84). The opioid neuropeptides influence the glutamatergic augmentation (both NMDA and non-NMDA receptors) of the respiratory discharge pattern. GABA and glycine are important in the inhibitory reciprocal control between respiratory neurons.

The complex neural interaction offers numerous possibilities for influence on respiration of pharmaceuticals. Naturally, the depressive effect of anesthetics has been of great interest in many studies. For instance, enflurane affect ventilation more than other inhaled volatile anesthetics (Derenne et al. '76; Lindahl and Johannesson '87; Murat et al. '95; Tanaka et al. '01). Barbiturates decrease the ventilation by means of an altered T_I/T_{TOT} ratio (Goldberg and Milic-Emili '77). Epidural morphine depresses the CO_2 response in both \dot{V} and $P_{0.1}$ (Doblar et al. '81). Fentanyl influences both minute ventilation, end tidal CO_2 and ventilatory response to CO_2 (Morisot et al. '89). Alfentanil has similar effects (Conti *et al.* '02).

The effect of ketamine is controversial and was investigated in combination with alfentanil in study V. Flumazenil reverses the ventilatory depression of benzodiazepines (Clergue et al. '81; Gross et al. '96) and aminophylline is a ventilatory stimulant (Sanders et al. '80). The neuromuscular relaxation of curarization does not necessarily impair $P_{0.1}$ as could be expected (Holle et al. '84).

Disease and breathing

CNS and neuromuscular disorders

Abnormalities in the neural control of ventilation are seen in a variety of pathologic states commonly seen in critical care.

Understanding interaction between drive and performance will hopefully lead to better understanding of the common pathologic processes (Malkoff and Borel '94).

Experiments of nature, such as tumors and strokes within the brainstem, has afforded some information; breathing is often affected surprisingly little while awake, and more severely during sleep (Nattie '99). In presenile dementia, such as Alzheimer's disease, lacking compensation to an added inspiratory resistive load has been reported (Derderian *et al.* '88). Two respiration-related CNS diseases that are discussed further below are congenital hypoventilation and sudden infant death syndromes.

In many neuromuscular disorders, such as poliomyelitis and myopathic diseases, the ventilatory response to CO₂ is depressed, but this does not in all instances imply an abnormal central control mechanism. Many patients with neuromuscular diseases have a normal respiratory drive (P_{0.1}) but a low ventilation because of abnormalities in muscle function and neuromuscular transmission. (Johnson and Kazemi '94). Increased respiratory drive and a faster breathing can be observed in patients with neuromuscular disease, which might be explained by the increase in neural afferent information from lung and/or rib cage (Scano *et al.* '93).

Lung disease

The poor ventilatory response to inhaled carbon dioxide in connection with lung disease is since long known (Brodovsky *et al.* '60). It is presumed that mechanical alterations of the respiratory apparatus have a fundamental role in the eventual build-up of CO₂ retention in patients suffering from severe chronic obstructive pulmonary disease (COPD). A chronic hypercapnia in turn is believed to cause a decreased chemosensitivity (response in

respiratory drive to CO₂) and further CO₂ retention (Lourenco and Miranda '68; Altose *et al.* '77; Gelb *et al.* '77; Tardif *et al.* '93), even if there are contesting reports (Montes de Oca and Celli '98) indicating a more unspecific neuroventilatory coupling failure.

In the normocapnic lung patient, however, especially the asthmatic, an increased respiratory drive is found, possibly to compensate for the airway obstruction (Cosgrove *et al.* '76; Zackon *et al.* '76; Neumeister *et al.* '96). These abnormalities are there even if the respiratory drive assessment can give lower values, due to exceptional volume and pressure conditions in the sick lung as discussed above (Marazzini *et al.* '77; Marazzini *et al.* '78).

The hypoxic ventilatory response is reduced in asthma (Hudgel *et al.* '79; Smith and Hudgel '80) and in the already hypoxic COPD patient (Bradley *et al.* '79) but compensated by an increased drive in asthmatic children (Morrill *et al.* '81). The hypoxic response is better preserved, in comparison to the hypercapnic response, but it is complex and depends on pattern and intensity of exposure (Powell *et al.* '98; Mitchell *et al.* '01). The chronic response to hypoxia includes growth of the carotid bodies and attenuation of their sensitivity, which may contribute to the deterioration in COPD (Bee and Howard '93).

Interstitial pulmonary disease is also associated with an increased respiratory drive (Launois *et al.* '91), and it has been suggested to use resting $\dot{V}/P_{0.1}$ as a clinical index to differentiate between normal subjects and patients with lung disease (Scott and Burki '90).

One interesting observation is the decreased variability of breathing in patients with restrictive lung disease (Brack *et al.* '02), which we also found in study III.

The presence of breathlessness and dyspnea is strongly associated with an increased drive, indicating mechanical impairment (Burki '79). The strategy should be to keep respiratory drive within a reasonable range to control the perception of dyspnea. Determining the response to chemical and mechanical stimuli will likely become important for predicting sensitivity of alarm reactions in patients

with lung disease (Hida '99; Marin *et al.* '99). Treatment alternatives to affect respiratory drive and perception of apnea in the lung patient include bronchodilators, corticosteroids, oxygen treatment, lung volume reduction surgery, pressure support ventilation, chest wall vibration (Hida '99) and maybe acupuncture (Neumeister *et al.* '99).

Sleep disorders

During sleep, ventilation is normally decreased. The reduction is more pronounced during REM (rapid eye movement) sleep, when there is a parallel reduction in respiratory drive (Douglas *et al.* '82a). Furthermore, there is a decrease in the ventilatory response to hypoxia and hypercapnia during sleep, and in the REM stage only about one third of the awake value (Douglas *et al.* '82b; Douglas *et al.* '82c). The respiratory drive is dominated by the chemical control, and in this regard there is no difference between REM and non-REM sleep (Meza *et al.* '98).

Most observations support the hypothesis that poor load compensation for an increased upper airway resistance contributes to the hypoventilation characteristic of normal sleep (White '86; Schwartz *et al.* '88; Wiegand *et al.* '88; King *et al.* '00). The activation of upper airway dilator muscles is primarily regulated through the intrapharyngeal pressure, with a fall in responsiveness during sleep (Malhotra *et al.* '00; Malhotra *et al.* '02), especially in men (Pillar *et al.* '00).

Respiratory related sleep diseases are characterized by one or several of the following: episodes of upper airway obstruction, sleep apneas, blood oxygen desaturation and hypercapnia.

Patients with OSAS (obstructive sleep apnea syndrome), which occur in both adults and children, do not exhibit the normal increase in neural drive to compensate for inspiratory flow-resistive loading (Rajagopal *et al.* '84; Marcus '00). The tendency of collapse of an unstable upper airway is aggravated by many drugs and alcohol (Dawson *et al.* '97).

Indexes that quantify the central inspiratory drive, such as $P_{0.1}$ reflect the activation of upper airway dilators in both OSAS patients and normals (Series *et al.* '89a, b). Fluctuations in the drive to breathe may adversely affect the upper airway patency and facilitate upper airway closure and obstructive apneas (De Backer '98). Better understanding of the mechanical properties of the upper airway in healthy subjects and patients should help in the development of new therapeutic strategies (Wheatley and Amis '98).

CSA (central sleep apnea) is a group of diseases that can be divided in two types; one is hypercapnic and related to hypoventilation or neuromuscular disease, the other has no identifiable underlying disorder. The common feature is recurrent episodes of sleep apnea related to withdrawal of the wakefulness drive to breathing (Bradley and Phillipson '92). Instability in the breathing pattern is the main underlying mechanism and is due to the interaction of many factors (De Backer '95).

The congenital central alveolar hypoventilation syndrome, CCHS, otherwise known as Ondine's curse, is a rare neuropathologic syndrome characterized by hypoventilation and periods of prolonged apnea. It is thought to represent a defect in central chemoreceptor function resulting in an inadequate respiratory drive (Strauser *et al.* '99), but the potential genetic and/or neuroanatomic basis of the syndrome is not known (Shirasawa *et al.* '00; Spengler *et al.* '01).

Sleep disorders are often treated with pressure support methods (McNicholas '97) Acetazolamide may have effect in CSA (De Backer '95).

SIDS

The mechanisms underlying the sudden infant death syndrome (SIDS) are not yet understood. Chemosensitivity seems to be normal, but there might be aberrations in the defense to mechanical loads (Lewis *et al.* '88; Milerad and Hellström '93) and in the interactive cardio-respiratory control (Hunt '92; Katz-Salamon and Milerad '98). SIDS risk is enhanced by the prone sleeping position (Fleming *et al.* '90), exposure to nicotine (Nachmanoff *et al.* '98),

thermal challenges and possibly other factors. The current view is that of an infant compromised by neural deficits and developmental delay in particular defense functions, such as arousal mechanisms, switch of sleeping state, the gasping function and the interaction between breathing and cardiovascular systems. This will create a handicap to compensate momentary challenges, with possibly fatal results (Harper *et al.* '00a).

Methods and materials

Setting

The occlusion pressure technique was brought to the department of medical engineering from the environmental physiology lab at Karolinska Institutet by professor Dag Linnarsson in the late 1980s . The methodology that was originally used at the environmental physiology lab is described elsewhere (Linnarsson and Hesser '78; Lind et al. '84). The interest at the department of medical engineering initially focused on the technique to perform brief occlusions and breath-by-breath measurements. Our resources were naturally engineering skills, *e.g.* programming, electronic and mechanical design. In addition to the Royal Institute of Technology in Stockholm, the department has close links with both Karolinska Hospital and Huddinge University Hospital. Special cooperation in parts of this project was established with some clinics at the Karolinska Hospital (the intensive care unit, the anesthesia department and the children's clinic) and Huddinge University Hospital (the intensive care unit, the anesthesia department, the pharmacology lab and the lung clinic).

Direct measurements

Pressure

Mouth pressure was recorded at the two-way valve or Y-piece, via a polyvinyl chloride tube (inner diameter 3 mm), by a 1) Validyne CD12-C transducer (Validyne Engineering, Northridge, CA; study I), 2) AutoTran series 600 transducer (AutoTran Inc, Eden Prairie, MN; study V, VII) and 3) Siemens SV 900 C build-in pressure transducers (Siemens-Elcoma, Stockholm, Sweden; study II-III, IV, VI). These transducers are all of high quality and have excellent

precision. Careful calibration and observance to a zero level drift, due to changes in ambient temperature, yield an accuracy better than 0.1-0.2 cm H₂O.

Flow

Flow recordings were made in the inspiratory limb by means of 1) a Fleisch type No 2 pneumotachograph (study I-II), 2) a venturi type transducer designed at the department (adult size orifice 10 mm; study V, VII) and 3) the Siemens SV 900 C built-in transducers (strain gauge type; study II- IV, VI). The differential pressures from the Fleisch and venturi transducers were measured with the Validyne and TransAuto pressure transducers, respectively. Compensation for the quadratic characteristics of the venturi transducer was made in the software. Calibrations were performed with a 3 l syringe (Hans Rudolph, Kansas City, MS), aiming at an accuracy better than 5 %.

CO₂ concentration

Respired CO₂ was measured by infrared capnography with a 1) Datex Normocap CO₂ & O₂ Monitor (Instrumentarium Corp, Helsinki, Finland; study I), 2) Engström Eliza Duo (Stockholm, Sweden; study II), and 3) Datex Oscar Oxy (Instrumentarium Corp, Helsinki, Finland; study III-VII). These instruments all use side-stream technique. The sampling flow, 100-200 ml/min, drawn from the Y-piece, was compensated for in the breath volume calculations. The end tidal value was defined in the software.

Breathing phase

Switches between breathing phases were determined from the operation of the occlusion valve. Valve opening was determined by means of 1) a light emitting diode (LED) and photo diode (study I-II, Figure 2), 2) directly from the inspiratory trigger signal which is available from the Siemens SV 900 C (study II-IV, VI), or 3) the

changes in the “vacuum” pressure signal (study V, VII; see “Equipment” below). The preceding occlusion time (see below), was included in the duration of inspiration. Start of expiration was determined similarly from the closing of the occlusion valve (study I-II, V, VII) and opening of the expiratory valve (study II- IV, VI).

Mechanical load

The setting of the inspiratory airway pressure was retrieved from the Siemens SV 900 C (study II-III). Access is achieved from the ‘PEEP level’ output.

P_{0.1} and calculations

The present algorithm

The calculation of P_{0.1} has to our knowledge been unique to this project. The algorithm was chosen as a consequence of our interest to measure on every breath without interfering with the breathing pattern. It differs from the customary technique (Whitelaw *et al.* '75), in the definition of the start and the end of the measuring interval, and that the occlusion can vary in duration. If the occlusion has a constant duration of 0.1 s, it would constitute an increasing share of the inspiratory time when breathing becomes faster or augmented. This represents an increasing risk for influence on the breathing. If the occlusion is terminated when a specified negative inspiratory threshold, instead of time, is exceeded, the load on the inspiratory effort would be limited and constant.

Another problem with the customary technique is the determination of onset of inspiration. Our experience of an often slowly increasing initial part of the pressure curve suggests that it is actually impossible to determine the time of onset with precision (Figure 1). Investigators have in reality defined the onset in terms of a pressure drop, *i.e.* a threshold, anyway – if they did not use

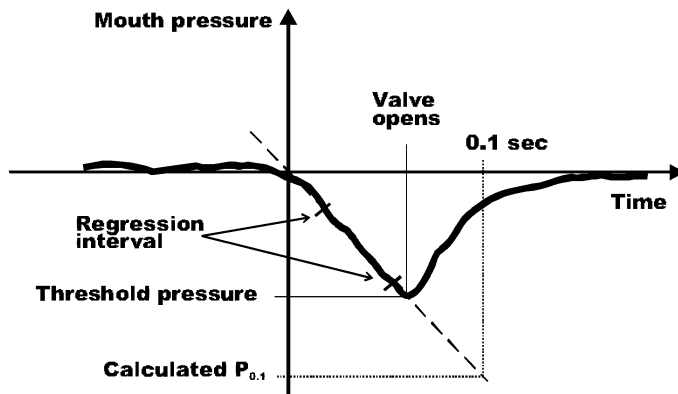

Figure 1. Time course of airway pressure during breath-by-breath transient occlusion at rest. $P_{0.1}$ is determined from the regression interval.

laborious subjective estimates by eye. The value of this “onset threshold” has not been standardized, making the application of $P_{0.1}$ determination a bit unclear.

The proposed method in study I is based on a pre-set negative threshold pressure, at which the occlusion valve is opened irrespectively of breathing effort (Figure 1), and on determination of $P_{0.1}$ on every breath. The threshold should be minor, and from experiments it was concluded that about one cm H₂O is appropriate. The occlusion time will then be adapted to the actual breathing effort; it can be less or more than 0.1 s.

As a consequence, the calculation of $P_{0.1}$ must be modified to yield estimates of $P_{0.1}$ only from the pressure signal preceding the valve opening. The present algorithm gives the slope of the pressure drop from linear regression of pressure versus time and presents results as the pressure drop per 0.1 s. The pressure and time interval for the regression is 30-90 % of the opening threshold pressure. This interval eliminates both the onset problem and influence of potential signal artifacts in connection with the valve opening.

Calculated parameters

Several parameters in addition to $P_{0.1}$ are calculated from the directly measured variables. These are:

- Occlusion time, T_O , calculated as the time between the zero pressure intercept of the occlusion pressure regression line and valve opening (see Figure 1).
- Inspiratory breathing time, T_I (T_O included).
- Expiratory breathing time, T_E .
- Breath duration, T_{TOT} , equals $T_I + T_E$.
- Breathing frequency, f , equals $60/(T_I + T_E)$.
- Tidal volume, V_T , is the integral of air flow during inspiratory time, corrected for the CO_2 sampling flow.
- Minute ventilation, \dot{V}_I , equals f times V_T .
- End tidal partial pressure of CO_2 in the airways, $ETCO_2$. Determined from the CO_2 signal.
- A few other special parameters were calculated in some of the studies.

Statistical methods

Minor editing of raw data was performed, eliminating extremely shallow (< 100 ml) and short breaths that obviously could not represent 'normal breaths'. Intra- and interindividual comparisons were made with Student's t -test or a generalized ANOVA model. Non-parametric tests (Wilcoxon signed ranks and one-way Friedman ANOVA) were preferred when assumptions for normal and symmetric distributions were not fulfilled. The SPSS and Statistica software were used for the evaluations. As customarily, a P -value < 0.05 was considered significant.

Equipment

Data acquisition

In our first equipment, here denoted Lab1 (study I-II), signals from the transducers were A/D converted on a laboratory designed circuit at a rate of 100 Hz and fed into a personal computer for further analysis. They were also backed up on a MR30 FM tape recorder (Teac Corp., Japan; study I-II), and later monitored on a Data Precision type Data 6000 signal analyzer (Analogic Corp., Danvers, MA), to perform manual determinations of $P_{0.1}$, for comparison. The later prototype Respimeter (RM) used a PC30 A/D card (Eagle Tech, Cape town, South Africa; study V, VII) for data acquisition, and the RM20 used a Multifunction PCMCIA-1200 Card (National Instruments Corp., Austin, TX). As for the Siemens SV 900 C (study II- IV, VI), the analogue signals from the ventilator's transducers were fed into a Servo Computer Module, SCM 990 (Siemens-Elema AB, Stockholm, Sweden). Irrespective of data acquisition, the analysis and presentation have been performed on personal computers.

Application of occlusions

The most common technique to occlude at inspiration is a manual stop-cock or an electronic shutter, the latter often controlling an inflatable balloon in lumen. The function should be silent, and, especially in the case of breath-by-breath measurement, have minimal influence on the breathing pattern. We therefore developed a combined inspiration and occlusion valve of a unique design (Figure 2; study I). In its passive mode, it is equivalent to a standard one-way valve, having an operating resistance of $< 1 \text{ cm H}_2\text{O l}^{-1} \text{ s}$. As an occlusion valve (active), a negative pressure is applied to the valve, and the amplitude of this "vacuum" determines the threshold to opening. When the threshold is exceeded, the valve again works as a standard inspiratory valve: both the resistance and the "vacuum" normalizes within milliseconds. The first design (Lab1, Figure 2) incorporated a light emitting and photo diode to

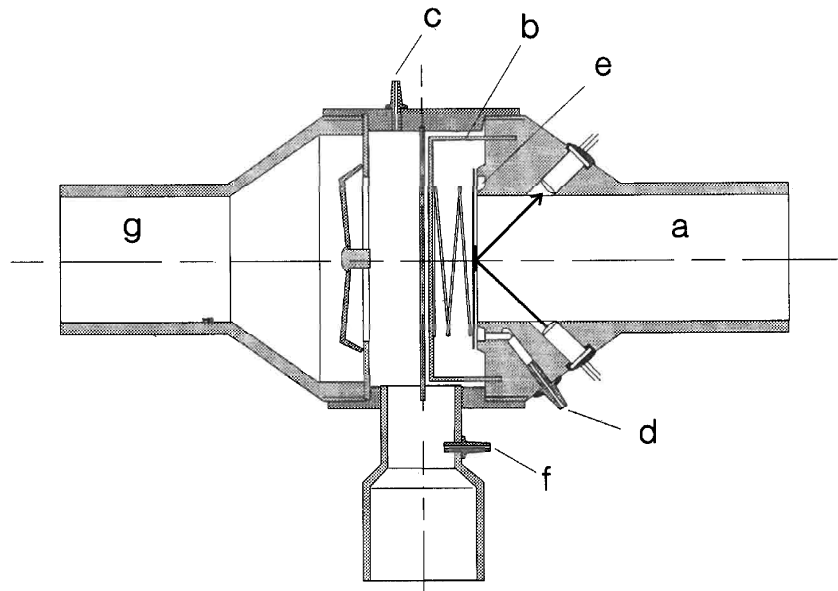

Figure 2. Cross section of combined inspiratory and occlusion valve. Explanations: a) inspiratory line; b) retainer cage for spring; c) to pressure sensor; d) to vacuum source; e) circular channel, where vacuum is created when inspiratory valve is closed; f) to CO₂ analyzer; g) expiratory line. The thick solid line indicates light from light emitting diode to photo diode (study I).

detect valve opening; this was later determined from the “vacuum” signal.

Working with this valve design, we soon realized that a ventilator, such as one we were using in other projects, in its spontaneous breathing modes, performs occlusions that can be used for P_{0.1} measurements with our algorithm. This led us into a clinical application of occlusion pressure measurements in addition to our dedicated equipment. The ventilator occludes the inspiratory line until a negative pre-set trigger pressure is exceeded in much the same way as our occlusion valve. The valve is in this case a pincer acting on a silicone duct, and the inspiratory pressure is actively controlled from the machine (the servo function). The servo control makes the concept of resistance during inspiration problematic (it is in theory zero) and the experience of a mechanical load is instead

dependent of the dynamic performance of the regulator. Moreover, mechanical loads can be applied from the machine - negative or positive inspiratory pressures - by a simple change of settings, and the resulting occlusion pressures in response to these loads can be studied.

A dedicated device

Our first instrument (Lab1), was a typical laboratory equipment. Regular high quality pressure and flow transducers were combined with the two-way valve described above. The equipment, including electronics and a capnometer, was integrated in a rack configuration on a trolley. A personal computer and a tape recorder completed instrumentation.

A later prototype (RM, Figure 3) was made in a series of three apparatuses. Pressure transducers and valve control components were mounted on a designed circuit board, included in a light weight case. The RM is powered and controlled from a personal computer, communicating via RS232 and the PC30 A/D card.



Figure 3. Measurements with the RM apparatus (in the background, on top of a Datex patient monitor) in a pharamcological study (V).

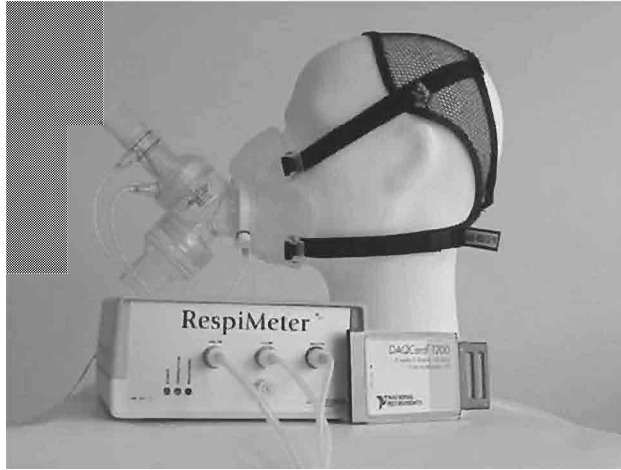

Figure 4 . The RM20 is a modernized version of the RespiMeter, with data acquisition through a PCMCIA plug-in card

A third and modernized version (RM20, Figure 4) was made upon a request from Pharmacia Upjohn. Ten apparatuses were sold to the company for pharmaceutical research. The RM20 have a modernized software and data acquisition, and is smaller than the RM. It has not been used in any of the papers presented in this dissertation.

A ventilator

The Servo Ventilator 900 C (Siemens-Elema AB, Stockholm, Sweden, Figure 5) was chosen for our studies, as brief occlusions are in fact applied on every breath in its spontaneous breathing modes (CPAP and Pressure support) before it is triggered by an inspiratory effort (pressure trigger). The pre-set trigger level is controlled by the knob “Trig. Sensitivity below PEEP”. The airway pressure signal is available from the ventilator.

Furthermore, a negative inspiratory pressure load is easily applied by adjusting the PEEP level below zero (expiratory pressure is not affected), and a positive inspiratory pressure load is applied using the pressure support mode. These easily available mechanical

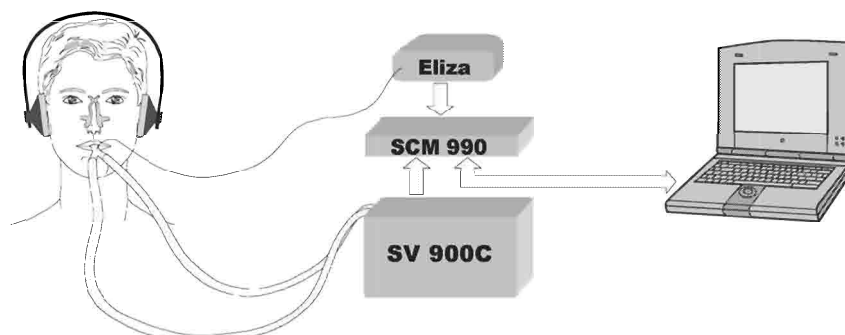

Figure 5. Set-up of apparatus. Analogue signals of airway pressure, flow and PEEP level from the ventilator, and carbon dioxide concentration from the capnometer (Eliza), were sampled and A/D converted by the Servo Computer Module, SCM. The breath parameters were retrieved, processed and displayed by a standard computer (study II-IV, VI).

challenges are achieved because this ventilator functions as a pressure regulator (servo). It supplies gas to the patient from a high pressure reservoir in response to a feedback from the airway pressure, which is measured in the inspiratory limb of the ventilator.

The SV 900 C is not unique in this sense, since all state-of-the-art ventilators work in a similar way. Our choice was based on the fact that we had access to the equipment, and that this is a common and clinically available ventilator on a world-wide scale. Our hypothesis was simply: can the ventilator replace a dedicated device to determine respiratory drive?

Critical factors would then be the speed of the regulator and other mechanical limitations, in comparison with the laboratory equipment. Our preliminary tests showed a high static expiratory resistance. To compensate for this in our studies (II- IV, VI), we removed the expiratory flow transducer and replaced the narrow silicone duct in the expiratory valve with a low-resistance latex hose. To minimize for slow regulator responses, the airway pressure measurement was extended from inside the ventilator to the “Y-piece” at the subject, and the working pressure was increased.

Later models of ventilators probably have better mechanical performance and signals available digitally. We have made preliminary studies on the Siemens SV300 (not included in this thesis) to retrieve breath-by-breath $P_{0.1}$. One question was whether it can be performed on a ventilator that is flow-triggered, *i.e.* the inspiration starts when a certain flow level is exceeded (see results below).

Breathing interface

Customary mouth breathing through a standard mouth piece was used in all studies except V and VII, where a face CPAP mask (Vital Signs, Totowa, NJ), allowing both mouth and nose breathing, was used.

Software

We have in our studies written our own software for data acquisition, analysis and presentation, working with standard personal computers. For the original laboratory equipment, BASIC programming language was preferred (Microsoft Corp), in combination with fast assembler routines for data acquisition (Lab1; I-II). For the SV 900 C platform, C programming (Microsoft C) was chosen (II- IV, VI), which suited the serial link with the SCM 990. For the RM prototype, C programming was complemented with an assembler kernel, to communicate with the A/D card. The software for the RM20 prototype is C++ (Borland), with the data acquisition software NI-DAQ (National Instruments, v6.7), to communicate with a PCMCIA Card (plug-in, for laptop computers).

One objective has been that the operator can follow the breathing process closely during experiments. Therefore the software design – data collection, calculation of secondary parameters, storage on a hard disk and presentation on a monitor – aimed at a real time working mode; results are presented on the screen breath-by-breath, or at the end of a procedure.

After experiments, results have been analyzed in different ways. The data files have been read into spreadsheet programs (Quattro, Excel), suitable to check, sort and make simple statistical calculations on breaths. Advanced statistical analysis has been performed in dedicated statistical packages.

Subjects and procedures

The experiments have mainly been made on healthy male volunteers (I-V). Males were preferred to avoid influence of menstruation cycle dependent hormones (Tatsumi '99). The subjects, who were ignorant of the purpose of the studies, were instructed to refrain from caffeine and nicotine before experiments. A comfortable, sitting or semi-recumbent position was mostly used. Exercise experiments were performed sitting on a cycle ergometer (II). The subjects were trained to the equipment before measurements started. They were listening to tape-recorded light stories or music via ear-phones to distract them from thinking about their breathing. The number of participants in the studies was mostly close to ten, which might be at the low end to discern a possible difference between experimental conditions, due to intra- and inter-individual variance in breathing variables. The dependence on the statistical analysis was thus essential. The studies were approved by the Ethical Committee of Karolinska Hospital or Huddinge University Hospital, and all subjects gave their informed consent.

For details of the experimental protocols, please refer to the specific paper.

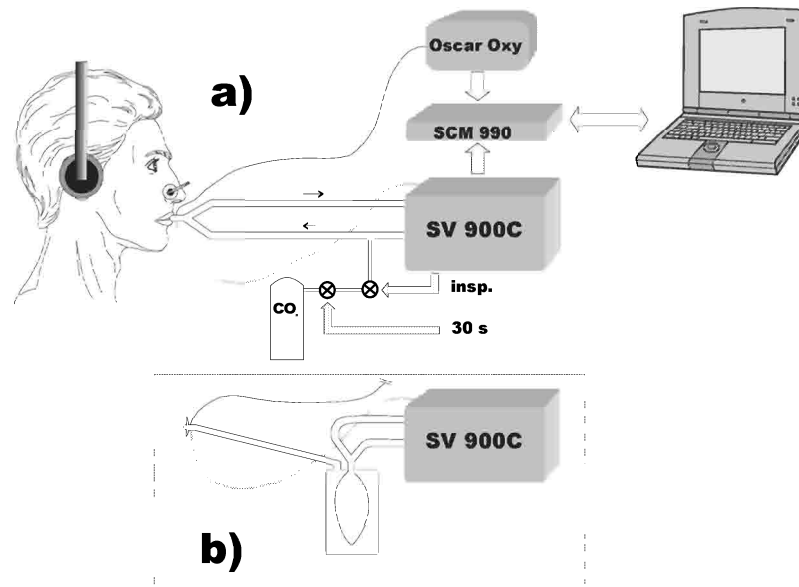

Figure 6. Setup of experiments. Subjects were spontaneously breathing on a ventilator, which was used to assess the breathing parameters. In the first test (a), pure CO₂ was administered in pulses with 30 seconds duration. A valve, that was controlled by the ventilator, opened the CO₂ inflow at inspiration and closed it at expiration. PCO₂ and airway pressure were recorded from the mouth-piece (study IV). In the second test (b), the subjects were re-breathing an O₂-N₂-CO₂ mixture. The ventilator was connected in a "bag-in-a-box" arrangement (illustrated in the dashed box; study IV, VI).

Challenges to breathing

CO₂ administration

The response to CO₂ stimulation have been investigated in the majority of the studies (IV-VII). All three types of provocations mentioned in the background have been used, *i.e.* rebreathing (IV, VI), step changes (VII) and transient pulses (IV, V).

In study IV, the customary rebreathing technique (Read '67) was adapted to breathing on a ventilator. In essence, the challenge must be halted at an early stage, as the high ventilation levels normally reached with this method cannot be achieved on this ventilator. The experimental set-up for applying rebreathing and the pulse method,

while breathing on a ventilator (study IV), is shown in Figure 6b. As illustrated, rebreathing was performed in a bag-in a-box arrangement. It should be noted that the subject is not breathing through the ventilator; it is only used for the flow- and pressure measurements.

The modified rebreathing was compared to an alternative pulse method (Jacobi *et al.* '89a, b), which also was modified and adapted to breathing on a ventilator (IV; Figure 6a). The aim was to find a less interfering test of the chemosensitivity. This technique was also used in study V, but then adapted to the dedicated apparatus RM (Figure 3). In short, pure CO₂ at a fixed flow is mixed with the inspiratory air flow during short (30 s) periods, in a repetitive manner. The transient response to these CO₂ pulses is measured as the peak or an integral of the ventilation before the next pulse. The response to a single pulse is small and variable, and believed to be more representative of the normal chemoregulation in comparison to rebreathing. This response can be averaged during a number of pulses to increase sensitivity.

The step change technique can be performed with a minimum of instrumentation. It was chosen for study VII.

Mechanical loading

The response to mechanical provocations was investigated in study II and III. It was based on the possibilities coming naturally with breathing on a ventilator: loads can be applied by simply adjusting the pressure control (see Equipment above). The response to mechanical stimuli reflects the activity of the central respiratory controller in a similar way as chemical stimulation. But as it affects other sensor mechanisms, the response is much faster.

Effects of positive and negative pressure loads (from - 6 to +6 cm H₂O) on breathing were investigated in study II. In study III, we were interested in the response to very small stimuli, closer to the natural control, and used a technique with very brief pulses, similar to the technique with pulses of CO₂ (study IV). The subjects were breathing on the SV 900 C, while the inspiratory pressure was

alternating between 0 and -2 cm H₂O, each level during 2 minutes. In study VII, a simple inspiratory resistance was applied by adding a 150 cm ventilator tubing to the inspiratory line.

Drug infusion

In study V, we investigated the ventilatory effect of two anesthetic agents in combination: alfentanil and ketalar. The major problem was the influence of ketamin; whether it would act as a stimulant or a depressant in the combination, in a dose range of interest for intensive care and pain-clinic setting. A plasma concentration of $50 \text{ ng}\cdot\text{ml}^{-1}$ of alfentanil was established through computer-controlled infusion. Then, a series of escalating ketamin levels ($50, 100, 200 \text{ ng}\cdot\text{ml}^{-1}$) were established similarly. The breathing was studied with the RM apparatus, using pulses of CO₂ for measurement of chemosensitivity.

The computer-controlled infusion ("Stanpump"; Scott *et al.* '85; Shafer *et al.* '88) aimed at a stable plasma concentrations in relation to the metabolic elimination. The pumps used for infusions were a Harvard 22 Basic Syringe Pump for the Stanford program (Harvard Apparatus, South Natick, MA) and a Syringe Minder-90 (KanMed, Järfälla, Sweden). Target level were later determined with chromatographic methods.

Effects of disease

SIDS: As mentioned in the background, there is still confusion on the causes of sudden infant death syndrome, SIDS. In a study not included in this thesis, we compared ventilatory responses to step changes in inhaled O₂ and CO₂ and negative inspiratory pressure (NIP) load in three groups: a) fathers of victims of SIDS, b) fathers of children that had experienced attacks of apnea and c) fathers of newborns with no reports of abnormal breathing (control). A SV 900 C ventilator was used to assess the respiratory parameters. The hypothesis was that victims of SIDS inherit an abnormal strategy of breathing from their parents.

COPD: Chronic obstructive pulmonary disease, COPD, is a classic field for $P_{0.1}$ studies. The reason is the possibility to differentiate between central and peripheral causes of breathing deficiencies. In study VI, we used our methodology in a prospective investigation on a group of 21 lung patients at Huddinge University Hospital. The aim was to study the long term development in these patients, the pattern of nocturnal hypoxemia ($S_pO_2 < 90\%$), the sleep quality, the respiratory drive and the CO_2 sensitivity. This was followed up by another study, not included in this thesis, on the effect of long term oxygen treatment (Sandek *et al.* '01).

A SV 900 C ventilator was used to assess the respiratory variables, while the patients were sitting in their wheelchairs. The resting level pattern was first recorded, and then a rebreathing session was performed.

Prader-Willi syndrome: The Prader-Willi syndrome, PWS, is a neurogenetic disorder in children. Among various symptoms of PWS, daytime somnolence and sleep apnea may occur. It has been shown that growth hormone, GH, has a positive effect on the growth and behavior of these patients (Lindgren *et al.* '97, '98). In study VII, the effect on breathing specifically was investigated in 9 PWS patients, before and after 6-9 months of GH treatment. The RM apparatus was used, and breathing was provoked by changes in inhaled O_2 , CO_2 and inspiratory resistance.

Results and discussion

Characteristics of breathing

Our experiments confirmed the large variability in breathing at rest. In study I, the coefficient of variation in the measured respiratory variables ranged during the various conditions between 16 and 35 %. Analysis of variance revealed that $P_{0.1}$ had the highest and T_{TOT} had the lowest variation of the measured variables. Of course a coefficient of variation in the order of 30 % renders intermittently obtained data less reliable than time averaged breath-by-breath data.

When the occlusion valve was switched between passive mode and active (retrieving $P_{0.1}$), and the latter between two levels of threshold pressure, it was apparent that the influence of the measurements on the breathing pattern was marginal, if any. Tidal volume, ventilation, breath duration and end tidal CO_2 did not differ between conditions. An analysis of variance of the time-course of $P_{0.1}$ values recorded immediately after activation of the occlusion valve could not differentiate between the first “loaded” breath and the following ten ($P_{0.1}$ can not be determined when the valve is in its

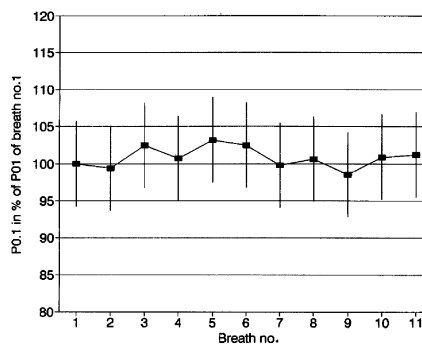

Figure 7. Time course of $P_{0.1}$ following the onset of 1.5 cm H_2O inspiratory threshold pressure at rest. Ensemble means of 12 transients for each of 9 subjects. Breath no. 1 is the first occluded breath. 95 % confidence intervals for means are indicated.

passive mode), indicating no change after activation (Figure 7).

Still, inspiratory duration decreased slightly and expiratory duration had a tendency to increase as the valve became active. This is opposite to what could be expected from a mechanical load. The difference might be an artifact from the way to determine the respiratory start and the more distinct closure of the valve when it is active.

Another finding is that $P_{0.1}$ became higher when the threshold pressure was raised from 0.7 to 1,5 cm H₂O. This could be interpreted as a response to a mechanical stimulus, but then again in contrast to the time-course analysis above. It is more probable that this is a consequence of a nonlinear pressure-time relation during occlusions (see Assessment of inspiratory activity in Background). We believe that the shape of the occlusion pressure curve normally is convex upwards, having an increasing gradient to the time axis. This can explain the results with different threshold pressures, and also the result of manual determinations falling between these.

It is not obvious what is a normal $P_{0.1}$ value at rest. There is a great variation in the literature of $P_{0.1}$. We believe that this variation reflects an underlying variation in experimental conditions, *e.g.* mechanical properties of the equipment, resting conditions during measurements, selection and position of the subjects, and the definition of “onset” of inspiration. This is not crucial, though, since what is normally measured is a possible change from an already preset experimental condition, using the same instrumentation.

Equipment

The laboratory equipment of study I, Lab1, was used as a reference in comparison with breathing on the Servo Ventilator 900 C in study II, see Table 1. From an analysis of variance, it was concluded that the breathing pattern at rest was the same in the

Table 1. Breathing on the ventilator in comparison with a dedicated low-resistance breathing circuit (Lab1), mean \pm SD (n = 9). Rest and dynamic leg exercise (50 W). Determinations were made on consecutive breaths, with inspiratory thresholds either 0.7 or 1.5 cm H₂O. Significant differences between the ventilator and the dedicated laboratory equipment are indicated (^a, ^b, ^c for p < 0.05, 0.01, 0.001, respectively, generalized linear model, repeated measures). Breath parameters: occlusion time (T_O), duration of inspiratory and expiratory phases (T_I and T_E), breathing frequency (f), tidal volume (V_T), minute ventilation (\dot{V}_I), end tidal value of airway carbon dioxide concentration (ETCO₂) and respiratory drive (P_{0.1}).

Threshold	Rest				50 W	
	Ventilator		Lab. equipment		Ventilator	Lab equip
	0.7	1.5	0.7	1.5	1.5	1.5
T _O [s]	0.10 \pm 0.03	0.19 \pm 0.06	0.13 \pm 0.06	0.17 \pm 0.06	0.09 \pm 0.03	0.08 \pm 0.03
T _I [s]	1.77 \pm 0.46	1.77 ^b \pm 0.38	1.43 \pm 0.28	1.41 \pm 0.26	1.83 ^c \pm 0.35	1.50 \pm 0.35
T _E [s]	2.71 \pm 0.62	2.75 \pm 0.69	2.73 \pm 0.63	2.86 \pm 0.70	2.53 ^a \pm 0.54	2.26 \pm 0.47
f [min ⁻¹]	13.85 \pm 2.52	13.69 \pm 2.40	14.94 \pm 2.77	14.55 \pm 2.52	14.20 ^a \pm 2.58	16.60 \pm 3.49
V _T [l]	0.65 \pm 0.12	0.65 \pm 0.09	0.62 \pm 0.09	0.63 \pm 0.08	1.54 \pm 0.28	1.43 \pm 0.24
\dot{V}_I [l/min]	8.90 \pm 1.31	8.79 \pm 1.49	9.26 \pm 1.33	9.29 \pm 1.50	21.39 ^b \pm 1.75	23.29 \pm 1.41
ETCO ₂ [%]	4.93 \pm 0.58	4.87 \pm 0.70	4.50 \pm 0.46	4.16 \pm 0.68	5.04 ^a \pm 0.49	5.36 \pm 0.39
P _{0.1} [cm H ₂ O]	1.05 \pm 0.29	0.98 ^c \pm 0.29	0.70 \pm 0.17	0.84 \pm 0.21	2.95 ^c \pm 0.93	1.54 \pm 0.30

ventilator except for inspiratory duration and P_{0.1}. Furthermore, an increased threshold pressure did not create significant changes.

During exercise (50 W), the difference between the laboratory equipment and the ventilator was more apparent. In addition to inspiratory duration and P_{0.1}, there were moderate differences in expiratory and frequency, ventilation and end tidal CO₂. The ventilator obviously exerts a mechanical load on breathing. It is minor and not easily discerned at rest, but as ventilation increases, it is disadvantageous for the ventilator as a measuring device. It can be explained by the inertia of the pressure-regulator of the ventilator and the resistance in the expiratory line. But if the

airway pressure is measured close to the subject and the expiratory resistance can be reduced, the performance of the ventilator is acceptable in a lower ventilatory range.

The fact that the coefficients of variation was somewhat lower breathing in the ventilator, except for $P_{0.1}$, can also be interpreted as a sign of a mechanical load.

The SV 900 C is an older model, and it is reasonable to believe that modern ventilators with improved technology have better mechanical performances. This has not been investigated in this project. What is known, though, is that modern ventilator technology adds additional complication as regards continuous $P_{0.1}$ determination. The use of a combined flow and pressure triggered start of inspiration may impede proper occlusion pressure recordings. Our preliminary tests show that the ventilator has to be run in the pressure trig mode to retrieve $P_{0.1}$ (Mårzell '99).

It should also be mentioned, when some ventilator manufacturers incorporate a $P_{0.1}$ option in their machines, that the results of our studies suggest a continuous, breath-by-breath determination of this variable, in preference to an intermittent manually imposed retrieval. One reason is the high variability, the other is the possibility to follow the breathing function over time, as part of the patient monitoring.

From the laboratory equipment Lab1, another two generations of devices were designed: The Respimeter (RM) was used in study IV and VII, and the RM20, which has not been used in this project. Contrary to Lab1, the Respimeters are small and portable and incorporate a modernized and more user-friendly software. But the occlusion valve technology and the low-resistance character is the same. The Respimeter is normally run with another more simple type of flow transducer (venturi), which due to its nonlinear characteristics needs signal processing and a more careful calibration.

The use of a CPAP face mask instead of a mouth piece is a more comfortable patient interface. But it is a modification of instrumentation that might slightly affect results, as it allows a

nasal breathing route, represents a small increase in dead space and compliance, and a possible source of leakage if mounted incorrectly.

Mechanical loading

It has already been discussed, whether the breath-by-breath determination of $P_{0.1}$ in our design could influence its own results. Anyway, the occlusion pressure technique is an interference by definition, even though measurements can be performed “unnoticed”, which was shown in study I.

In study II, mechanical loads were exerted on breathing at both rest and exercise. Negative and positive inspiratory pressures were applied in a randomized pattern from the SV 900 C. The compensatory mechanisms to the mechanical stimulus is illustrated in Figure 8. A negative inspiratory pressure resembles a resistive load (like breathing through a straw) and a positive inspiratory

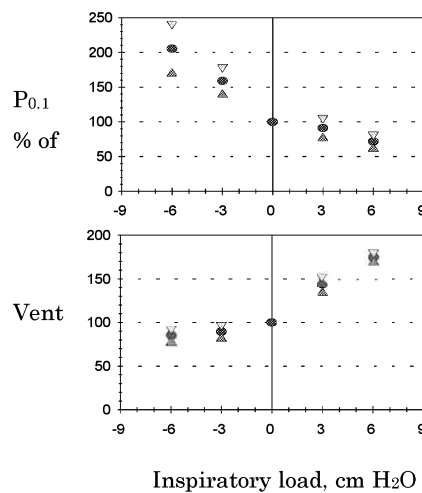

Figure 8. Relative changes of central inspiratory activity ($P_{0.1}$) and ventilation (\dot{V}_I). Mean \pm standard error of mean ($n = 9$) for responses to inspiratory pressure loading in percent of individual controls without loading.

pressure resembles a resistive unload (can only be performed from some laboratory equipments or by breathing Helium). But one principal difference is that a pressure load more specifically affects the inspiratory activity *per se*; there is not much trade-off in a change of respiratory timing, which there is breathing against a resistance. This could be seen as an advantage if the purpose is to study the sensitivity of the central respiratory controller. The advantage, in comparison to breathing CO₂, is the rapid ventilatory response and the simple accomplishment on the ventilator.

The regulation in response to small mechanical stimuli was investigated in study III. The transient response to these negative inspiratory pressure (NIP) pulses could not be directly seen in the breathing pattern, as it was smaller than the natural variability. But ensemble-averaging of six consecutive NIP pulses, gave the results of Table 2, where “Normal” is the no NIP period and “Stimulated” represents an integrated average during the NIP sequence period. The “Baseline” represents measurements without any mechanical loads (control). Analysis of variance revealed, that there was no measurable response in P_{0.1} to these small stimuli, resulting in decreased ventilation during pulses. Since this is in contrast to the results of study II, where the respiratory drive increased, we conclude that there is a sensitivity threshold in the range -2 to -3 cm H₂O for NIP.

Table 2. Breathing response to repeated pulses of negative inspiratory pressure (NIP), presented as mean and standard deviation in respective intervals. Baseline: no pressure load; Normal: between loads; Stimulated: integrated average during full NIP sequence.

	Ventilation	CV ^a	P _{0.1}	CV ^a	ETCO ₂
Baseline	9.28 ± 1.50	0.19	1.06 ± 1.31	0.51	5.21 ± 0.43
NIP	8.30 ± 1.11	0.10	1.14 ± 0.49	0.22	
Normal	9.53 ± 1.33	0.12	1.19 ± 0.42	0.23	5.25 ± 0.50
Stimulated	8.91 ± 1.18		1.16 ± 0.44		

^a Coefficient of variation

More interesting maybe is that from these data, that do not deviate from the normal range of flows and pressures in thorax, there was a significant reduction in the variability in both ventilation and respiratory drive during NIP periods. This is similar to what happens in a patient with restrictive lung disease, such as pulmonary tuberculosis or pneumonitis (Brack *et al.* '02), and physically a natural consequence of an increased stiffness of the lungs. Patients with obstructive lung disease, on the other hand, has an increased coefficient of variation. This finding suggests that a lung dysfunction can temporarily be simulated in a patient with NIP loading. NIP can be regarded as an artificially imposed reduction of the lung compliance (decreased dV/dP), whereas a resistive load adds resistance to the system.

This is an interesting example of how mechanical loads affect other physiological mechanisms than chemostimulation does.

Carbon dioxide sensitivity

The sensitivity to CO_2 was measured in study IV-VII. In IV, rebreathing and the pulse method were adapted for the SV 900 C ventilator. In V, the pulse method was used with the RM. In VI, rebreathing was used with the ventilator. And in VII, the steady-state method was used with the RM.

The rebreathing method, which was presumed unsuitable for breathing on a ventilator, gave results that matched the literature references surprisingly well (Table 3). This was in spite of the fact that, due to the mechanical limitations of the ventilator, rebreathing was in average halted in about half the time recommended (Read '67). In the present application, calculations are only based on the linear portion of the ventilation versus PCO_2 relation, *i.e.* after 30 s of equilibration and before the curve is bending following the increased mechanical load of the ventilator.

The subjects were also exposed to the CO_2 pulse method, while breathing on the ventilator. The major difference to rebreathing,

Table 3. Rebreathing CO₂ on a ventilator. Comparison of response, measured as gradient (linear increase in response to change of airway concentration of CO₂) in inspired ventilation (\dot{V}_I), and respiratory drive ($P_{0.1}$).

	$\Delta \dot{V}_I / \Delta P_{CO_2}$ [l min ⁻¹ % ⁻¹]	$\Delta P_{0.1} / \Delta P_{CO_2}$ [cm H ₂ O 0,1s ⁻¹ % ⁻¹]	No of subjects
This study	23,5 ± 10,8	2,3 ± 1,7	10
Read (1967)	20.1 ± 9.2	-	21
Cherniack <i>et al.</i> (1976)	22.7 ± 13.9	4.6 ± 0.8	14

is that the transient ventilatory response to the CO₂ pulses never brings ventilation far from the control baseline level. This can be seen in Table 4, where another difference is also obvious: rebreathing has an impact on respiratory timing as well. This represents a change from range 1 to range 2 in respiratory control, according to Clark and von Euler ('72). The probably most relevant effect parameter for the pulses is the Stimulated value, representing an integrated average of the response during the pulse period, but it can also be problematic if there is a drift in the baseline of ventilation (Jacobi *et al.* '89b).

Comparing three possible ways to stimulate with CO₂, the rebreathing method has the highest sensitivity (expressed as $\Delta \dot{V} / \Delta P_{CO_2}$), and the pulse method has the lowest sensitivity (which can be understood from the fact that the ventilatory response lags behind the, transient, change in P_{CO₂}). The steady-state method is intermediate, depending on the chosen concentration of inhaled CO₂. It is slow but reliable and easy to perform. The pulse method is presumably more representative of normal regulation, closer to control. It does not impose great challenges on either the patient or the equipment. It probably primarily reflects the regulation of the peripheral chemoreceptors, due to the rapid and transient character of the stimulus. With the pulse method, it is also possible to follow

Table 4. Change of breathing in response to CO₂. Summary of experiments with intermittent pulses of CO₂ and re-breathing, mean ± standard deviation.

	T _I [s]	T _E [s]	T _I / T _{TOT}	V _T [l]	\dot{V}_I [l]	P _{0.1} [cm H ₂ O 0,1 s ⁻¹]	ETCO ₂ [%]
<u>Baseline</u>	1.66 ± 0.39	2.53 ± 0.62	0.40 ± 0.05	0.61 ± 0.08	9,1 ± 1,7	1,03 ± 0,58	5,2 ± 0,4
<u>From pulses</u>							
Stimulated value	1.63 ± 0.36	2.40 ± 0.58	0.41 ± 0.05	0.64* ± 0.07	10,1* ± 1,7	1,20* ± 0,64	-
Peak value	1.65 ± 0.31	2.32* ± 0.72	0.42 ± 0.05	0.85* ± 0.14	13,4* ± 2,9	1,68* ± 0,92	6,0* ± 0,7
<u>Re- breathing</u>							
First 3	1.46* ± 0.26	2.02* ± 0.54	0.42 ± 0.06	1.00* ± 0.16	17,5* ± 2,8	1,27* ± 0,87	7,2* ± 0,4
Last 3	1.38* ± 0.19	1.60* ± 0.38	0.47* ± 0.05	1.83* ± 0.35	36,9* ± 5,1	2,96* ± 0,83	8,2* ± 0,6

* indicates significant changes in respect to baseline ($p < 0.05$, Wilcoxon).

T_I: inspiratory time; T_E: expiratory time; T_I / T_{TOT}: duty time; V_T: tidal volume; \dot{V}_I : inspired ventilation; P_{0.1}: respiratory drive; ETCO₂: end tidal airway concentration of carbon dioxide; Baseline: before stimulation; Stimulated value/Peak value: integrated average/maximal value during pulse sequence; First 3/Last 3: average of the first/last three breaths of linear portion during rebreathing.

changes in the CO₂ sensitivity in a continuous, monitoring way.

Our conclusion is that all three methods to stimulate with CO₂ can be adapted to breathing on a ventilator. Considering the relatively high quality of measurements in modern advanced ventilators, this is surely an option for the clinical setting, which is poorly recognized and used. The possibilities to study ventilatory response to CO₂ is of course also open with a dedicated device, such as the Respimeter (study V, VII).

Effect of drugs

The major finding of our experiments with drug infusion in study V is illustrated in Figure 9. As subjects received a stable alfentanil plasma concentration, their ventilation decreased significantly. The depressant effect was neither reflected in the inspiratory activity *per se* ($P_{0.1}$) or the sensitivity to CO_2 . The difference was in timing: a prolongation of expiratory, but not inspiratory duration. This caused an increase in end tidal CO_2 and a reduced S_pO_2 .

The effect of the escalating levels of ketamine infusion was the opposite; it reversed the alfentanil-induced changes in breathing. This effect was not present in the placebo group of this double-blind study. It can only be speculated whether the reversal effect is a result of a supra-pontine arousal – all subjects experienced probable ketamine-related side-effects – or a drug-related change at the receptor-level in specific respiratory pathways in the CNS.

It should be observed that the effects shown are very much related to the chosen plasma concentrations. Higher or lower doses could yield different results. One conclusion of our studies (II, IV-V) may be that the depressant drug alfentanil primarily acts on respiratory timing, whereas chemo- and mechano-stimulation (see

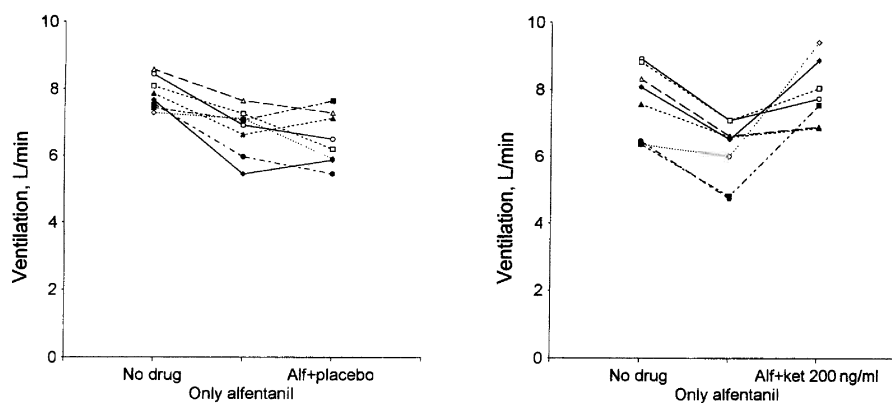

Figure 9. Minute ventilation in all subjects in period 1 (baseline, no drugs), period 2 (only alfentanil, 50 ng ml⁻¹) and period 5 (left pane: alfentanil plus placebo; right pane: alfentanil plus ketamin, 200 ng ml⁻¹; study V).

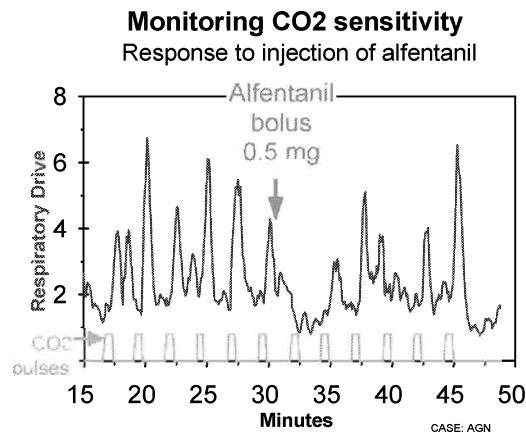

Figure 10. The RM used as a monitor of the respiratory activity. This is a breath-by-breath recording of $P_{0.1}$. The response to repeated pulses of carbon dioxide was recorded for one subject. It demonstrates the effect of a bolus dose of a drug with short effect-latency and duration.

above) primarily acts on the respiratory drive. But with an increasing dose, other effects are added. To illustrate this further, a case trial is shown in Figure 10, where the subject received a bolus of 0.5 g alfentanil and the sensitivity to consecutive CO₂ pulses was recorded. This also illustrates the possibility to monitor time-courses with the present technique.

Disease and breathing

SIDS

From our investigation on fathers of SIDS infants it was found that they did not differ from controls in their ventilatory response to hyperoxia and to hypercapnia. However, the SIDS fathers did not increase respiratory drive and maintain minute ventilation in the same way as controls during negative inspiratory pressure loading. It was suggested that a disability to compensate for added inspiratory loading carry an increased risk of SIDS in the offspring (Milerad and Hellström '93) .

COPD

Study VI (Figure 11) showed that nocturnal hypoxemia may persist unaltered for at least one year without the development of daytime hypoxemia. Important defense mechanisms, maintaining high minute ventilation and preventing progressive sleep-related hypoxemia, may be a superficial sleep in combination with frequent sleep stage changes and a high CO₂ sensitivity.

The study confirmed that COPD patients tend to preserve their respiratory drive in response to CO₂ ($dP_{0.1}/dETCO_2$ was 1.8 cm H₂O kPa⁻¹ during rebreathing), which was close to normal controls (2.3 cm H₂O kPa⁻¹). But they suffer from a strongly reduced ventilatory response ($d\dot{V}/dETCO_2$ was 3.7 l min⁻¹ kPa⁻¹), in comparison to normal controls (23.6 l min⁻¹ kPa⁻¹). In the sub-group, that eventually developed daytime hypoxemia (PaO₂ < 8 kPa), the lung function was poorer, and their ventilatory response to hypercapnia was virtually absent (0.5 l min⁻¹ kPa⁻¹).



Figure 11. Setting of rebreathing while breathing on a ventilator (study VI). The COPD patients were sitting in their wheelchairs while breathing in a “bag-in-a-box” arrangement (see also Figure 6).

In a follow-up on the effect of long term oxygen treatment of hypoxemic COPD patients (Sandek *et al.* '01), there were few changes during the six months treatment. A poor ventilation/perfusion ratio and a probable shunting were contributing factors for the reduction of PaO₂. The hypercapnic ventilatory response, which was about one fifth of normal in these hyperinflated patients, is a major determinant of the PaCO₂ level. Also in this patient group, there is no evidence of a central dysfunction in the CO₂ sensitivity. The baseline resting P_{0.1} was actually higher in the patient group, which is the presumed normal response to the mechanical impairment.

Prader-Willi syndrome

The effect of growth hormone, GH, on breathing in PWS patients was profound (study VII). There was a marked increase in both resting ventilation and central inspiratory drive after 6-9 months of treatment. Most striking was the increase in CO₂ sensitivity, see Figure 12. Still, the very low CO₂ sensitivity, that characterizes PWS was only partly normalized, in comparison to normal subjects. The mechanisms behind this effect of GH is difficult to explain. It can not be understood from pure somatic growth or the obesity of the patients. There was no change in the response to mechanical load or to hyperoxia. It is more likely that GH, like some other hormones, has a specific effect on the central nervous system and the control of breathing, which is not fully understood.

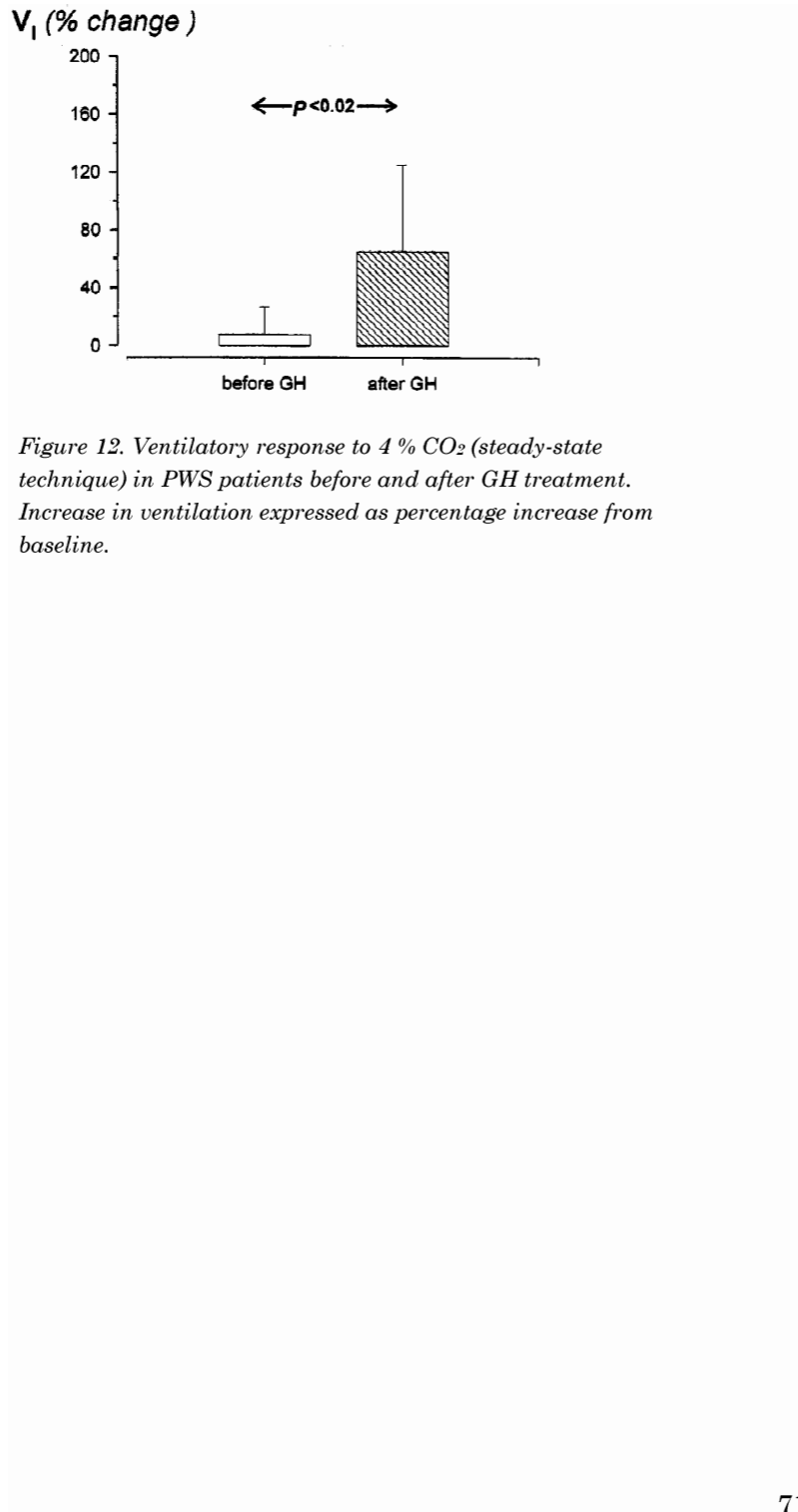

Figure 12. Ventilatory response to 4 % CO_2 (steady-state technique) in PWS patients before and after GH treatment. Increase in ventilation expressed as percentage increase from baseline.

Conclusions

It is widely accepted that $P_{0.1}$ is a valid method to assess respiratory drive in humans, though the practical application is not fully standardized. Measurement of $P_{0.1}$ is easily performed in comparison to alternative methods. $P_{0.1}$ complements other respiratory variables, often in connection with measuring the ventilatory adjustment to a disturbance.

The major conclusions of this project are:

- $P_{0.1}$ measurement is characterized by a high temporal variability, which would favor breath-by-breath measurement.
- Breath-by-breath determination of $P_{0.1}$ can be performed without influence on the breathing pattern if the mechanical impedance of the equipment is limited. The proposed method in this project is functional in that aspect.
- The proposed method can be implemented while the subject is breathing on a ventilator, as an alternative to using a dedicated device.
- Mechanical loads of the ventilator increasingly influence the breathing pattern at exercise.
- Pressure loading applied from the ventilator can be utilized to study the function of a subject's respiratory controller.
- Ventilatory adjustments to loads, whether chemical or mechanical, can be achieved in different ways with the proposed method. Breathing on a ventilator was shown to be compatible with all the tested methods for provocation of breathing.
- During alfentanil infusion and lung disease respiratory drive was maintained in spite of an impaired ventilation. It was altered due to mechanical loads and GH treatment of Prader-

Willi patients. Respiratory drive should be regarded as a respiratory parameter in its own right, reflecting an exclusive aspect of breathing.

- Respiratory drive assessment provides added diagnostic or therapeutic values in several specific medical situations, and can be accomplished without a complicated or invasive technique.

Acknowledgements

I want to express my deep gratitude to all those who helped me with this thesis. In particular I want to thank:

Jan Persson, my chief supervisor, co-author and friend, who paved the way for me in so many ways and supported me with abundant enthusiasm.

Dag Linnarsson, co-supervisor, co-author, and introducer of the project subject, who for many years has shared his scientific wisdom and physiological skills with me.

Håkan Elmquist, my chief and co-supervisor, for giving me the possibility to doctorate, teaching me creativity in engineering and how to see opportunities.

Hans Larsson, co-author, old friend and colleague, who can make equipment work against all reason.

Tommy Ribbe and **Jan Bergholm**, colleagues and friends at the division of medical engineering; without their technical assistance this project would have been nothing.

Krister Tham, **Anna Mårzell** and **Filip Wahlberg**, M Sc students, who in their thesis works made valuable contributions to the project.

Josef Milerad, co-author and friend, who introduced me to the pathology of respiration and to clinical research.

Börje Hallén and **Michael Lagerkrantz**, who also provided me with expertise and opportunities for clinical trials.

Karin Sandek and **Tomas Bratel**, co-authors, who opened the world of lung medicine for me.

Lars L Gustafsson and **Harry Scheinin**, co-authors, two exemplary scientific workers for me; one in the joy of science, the other in the beauty of precision and focus.

Eva Götharson, for superb nursing assistance.

Patients and subjects, for their cooperation and patience.

I also want to thank all my **colleagues** at the division of medical engineering for their support and for creating the innovative and spiritual atmosphere and many enlightening discussions. Special thanks to **Camilla Carlsson, Emil Söderquist** and **Camilla Storaa** for taking over parts of my duties to help me finish this work.

Bertil Jacobson, my former chief, friend and prime teacher, who introduced me to biomedical engineering, and made me understand the importance of scientific curiosity and dedicating oneself on fulfilling a great task.

My parents, **Julia** and **Gunnar**, who always believed in me.

And finally, most of all, my family, **Margita, Petter, Erik** and **Arvid**, who always had sufficient love and patience, accepting me for what I am.

Grants

Financial support for this project has been supplied by the Swedish National Board for Technical Development (STU), no 623-90-01177 and 623-91-020778, AGA AB Medical Research Fund and Karolinska Institutet.

References

- Akahoshi, T., White, D. P., Edwards, J. K., Beaugard, J. and Shea, S. A. (2001). "Phasic mechanoreceptor stimuli can induce phasic activation of upper airway muscles in humans." *J Physiol* **531**(Pt 3): 677-91.
- Alberti, A., Gallo, F., Fongaro, A., Valenti, S. and Rossi, A. (1995). "P0.1 is a useful parameter in setting the level of pressure support ventilation." *Intensive Care Med* **21**(7): 547-53.
- Altose, M. D., Kelsen, S. G. and Cherniack, N. S. (1975). "Effects of transient flow resistive loading and unloading on inspiratory muscle force (abstract)." *Physiologist* **18**: 120.
- Altose, M. D., Kelsen, S. G., Stanley, N. N., Levinson, R. S., Cherniack, N. S. and Fishman, A. P. (1976). "Effects of hypercapnia on mouth pressure during airway occlusion in conscious man." *J Appl Physiol* **40**: 338-44.
- Altose, M. D., McCauley, W. C., Kelsen, S. G. and Cherniack, N. S. (1977). "Effects of hypercapnia and inspiratory flow-resistive loading on respiratory activity in chronic airways obstruction." *J Clin Invest* **59**: 500-07.
- Altose, M. D., Kelsen, S. G. and Cherniack, N. S. (1979). "Respiratory responses to changes in airflow resistance in conscious man." *Respir Physiol* **36**: 249-60.
- Andriano, M. D., Pace, N. L., Westenskow, D. R. and Stanley, T. H. (1983). "Measurement and evaluation of breath-to-breath mouth occlusion pressures in normal humans during carbon dioxide rebreathing (abstract)." *Am. Rev. Respir. Dis.* **125**: 266.
- Appendini, L., Purro, A., Gudjonsdottir, M., Baderna, P., Patessio, A., Zanaboni, S., Donner, C. F. and Rossi, A. (1999). "Physiologic response of ventilator-dependent patients with chronic obstructive pulmonary disease to proportional assist ventilation and continuous positive airway pressure." *Am J Respir Crit Care Med* **159**(5 Pt 1): 1510-7.
- Ballantyne, D. and Scheid, P. (2001a). "Central chemosensitivity of respiration: a brief overview." *Respir Physiol* **129**(1-2): 5-12.
- Ballantyne, D. and Scheid, P. (2001b). "Central respiratory chemosensitivity: cellular and network mechanisms." *Adv Exp Med Biol* **499**: 17-26.
- Bee, D. and Howard, P. (1993). "The carotid body: a review of its anatomy, physiology and clinical importance." *Monaldi Arch Chest Dis* **48**(1): 48-53.
- Bellingham, M. C. (1998). "Driving respiration: the respiratory central pattern generator." *Clin Exp Pharmacol Physiol* **25**(10): 847-56.
- Bellville, J. W., Whipp, B. J., Kaufman, R. D., Swanson, G. D., Aqleh, K. A. and Wiberg, D. M. (1979). "Central and peripheral chemoreflex loop gain in normal and carotid body-resected subjects." *J Appl Physiol* **46**(4): 843-53.
- Beral, V. and Read, D. J. (1971). "Insensitivity of respiratory centre to carbon dioxide in the Enga people of New Guinea." *Lancet* **2**(7737): 1290-94.
- Berger, A. J., Mitchell, R. A. and Severinghaus, J. W. (1977). "Regulation of respiration: (second of three parts)." *N Engl J Med* **297**(3): 138-43.

- Bianchi, A. L., Denavit-Saubie, M. and Champagnat, J. (1995). "Central control of breathing in mammals: neuronal circuitry, membrane properties, and neurotransmitters." *Physiol Rev* **75**(1): 1-45.
- Boden, A. G., Harris, M. C. and Parkes, M. J. (2000a). "The preoptic area in the hypothalamus is the source of the additional respiratory drive at raised body temperature in anaesthetised rats." *Exp Physiol* **85**(5): 527-37.
- Boden, A. G., Harris, M. C. and Parkes, M. J. (2000b). "A respiratory drive in addition to the increase in CO₂ production at raised body temperature in rats." *Exp Physiol* **85**(3): 309-19.
- Brack, T., Jubran, A. and Tobin, M. J. (2002). "Dyspnea and decreased variability of breathing in patients with restrictive lung disease." *Am J Respir Crit Care Med* **165**(9): 1260-4.
- Bradley, C. A., Fleetham, J. A. and Anthonisen, N. R. (1979). "Ventilatory control in patients with hypoxemia due to obstructive lung disease." *Am Rev Respir Dis* **120**(1): 21-30.
- Bradley, T. D. and Phillipson, E. A. (1992). "Central sleep apnea. [Review] [52 refs]." *Clin Chest Med* **13**(3): 493-505.
- Brenner, M., Mukai, D. S., Russell, J. E., Spiritus, E. M. and Wilson, A. F. (1990). "A new method for measurement of airway occlusion pressure." *Chest* **98**: 421-27.
- Brodovsky, D., MacDonell, J. A. and Cherniack, R. M. (1960). "The respiratory response to carbon dioxide in health and emphysema." *J Clin Invest* **39**: 724-29.
- Brogan, W. (1990). *Modern Control Theory*, Prentice Hall.
- Burke, W. E. and Mekjavic, I. B. (1991). "Estimation of regional cutaneous cold sensitivity by analysis of the gasping response." *J Appl Physiol* **71**(5): 1933-40.
- Burki, N. K., Mitchell, L. K., Chaudhary, B. A. and Zechman, F. W. (1977). "Measurement of mouth occlusion pressure as an index of respiratory centre output in man." *Clin Sci Mol Med* **53**: 117-23.
- Burki, N. K. (1979). "Breathlessness and mouth occlusion pressure in patients with chronic obstruction of the airways." *Chest* **76**(5): 527-31.
- Campbell, E. J. M., Dickinson, C. J., Dinnick, O. P. and Howell, J. B. L. (1961). "The Immediate Effects of Threshold Loads on Breathing on Men and Dogs." *Clin. Sci.* **21**: 309-20.
- Capdevila, X. J., Perrigault, P. F., Perey, P. J., Roustan, J. P. and d'Athis, F. (1995). "Occlusion pressure and its ratio to maximum inspiratory pressure are useful predictors for successful extubation following T-piece weaning trial." *Chest* **108**(2): 482-89.
- Cherniack, R. M. and Snidal, D. P. (1956). "The effect of obstruction to breathing on the ventilatory response to CO₂." *J Clin Invest* **35**: 1286-90.
- Cherniack, R. M. (1959). "The oxygen consumption and efficiency of the respiratory muscles in health and emphysema." *J Clin Invest* **38**: 494.
- Clark, F. J. and von Euler, C. (1972). "On the regulation of depth and rate of breathing." *J. Physiol. (Lond.)* **222**(2): 267-95.

- Clergue, F., Desmonts, J. M., Duvaldestin, P., Delavault, E. and Saumon, G. (1981). "Depression of respiratory drive by diazepam as premedication." Br J Anaesth **53**: 1059-63.
- Conti, G., De Blasi, R., Pelaia, P., Benito, S., Rocco, M., Antonelli, M., Bufi, M., Mattia, C. and Gasparetto, A. (1992). "Early prediction of successful weaning during pressure support ventilation in chronic obstructive pulmonary disease patients." Crit Care Med **20**(3): 366-71.
- Conti, G., Pierdominici, S., Ferro, G., Bocci, M. G., Antonelli, M. and Proietti, R. (2002). "Effects of low-dose alfentanil administration on central respiratory drive and respiratory pattern in spontaneously breathing ASA 1 patients." Anaesthesia **57**(6): 540-3.
- Cosgrove, J. F., Neuburger, N. and Levison, H. (1976). "The ventilatory response to carbon dioxide in asthmatic children, measured by the mouth-occlusion method (Pm100)." Pediatrics **57**(6): 952-9.
- Cruz, J. C. and Zeballos, R. J. (1975). "[Racial influence on the ventilatory response to hypoxia and hypercapnia (author's transl)]." Acta Physiol Lat Am **25**(1): 23-32.
- Dawson, A., Bigby, B. G., Poceta, J. S. and Mitler, M. M. (1997). "Effect of bedtime alcohol on inspiratory resistance and respiratory drive in snoring and nonsnoring men." Alcoholism **21**(2): 183-90.
- De Backer, W. A. (1995). "Central sleep apnoea, pathogenesis and treatment: an overview and perspective. [Review] [119 refs]." Eur Respir J **8**(8): 1372-83.
- De Backer, W. A. (1998). "Methods and clinical significance of studying chemical drives." Respir Physiol **114**(1): 75-81.
- De Backer WA (1998). "Methods and clinical significance of studying chemical drives." Respir Physiol **114**(1): 75-81.
- DeGoede, J., Berkenbosch, A., Ward, D., Bellville, J. and Olievier, C. (1985). "Comparison of chemoreflex gains obtained with two different methods in cats." J Appl Physiol **59**(1): 170-79.
- Dejours, P., Labrousse, Y., Raynaud, J., Girard, F. and Teillac, A. (1958). "Stimulus oxygène de la ventilation au repos et au cours de l'exercice musculaire, a basse altitude (50 m), chez l'homme." Rev Fr Etud Clin Biol **3**: 105-23.
- Delavault, E., Saumon, G. and Georges, R. (1984). "Automatic monitoring of breath-to-breath occlusion pressure and ventilatory parameters during CO2 rebreathing." J Biomed Eng **6**: 3-8.
- Derby, C. D. and Steullet, P. (2001). "Why do animals have so many receptors? The role of multiple chemosensors in animal perception." Biol Bull **200**(2): 211-5.
- Derderian, S. S., Rajagopal, K. R. and Jabbari, B. (1988). "Respiratory control in presenile dementia." Am Rev Respir Dis **137**(1): 158-61.
- Derenne, J., Couture, J., Iscoe, S., Whitelaw, A. and Milic-Emili, J. (1976). "Occlusion pressures in men rebreathing CO2 under methoxyflurane anesthesia." J Appl Physiol **40**(5): 805-14.
- Derenne JP, Macklem PT and Roussos C (1978). "The respiratory muscles: Mechanics, control, and pathophysiology. Part 2." Am Rev Respir Dis **118**(2): 373-90.

- Doblar, D. D., Muldoon, S. M., Abbrecht, P. H., Baskoff, J. and Watson, R. L. (1981). "Epidural morphine following epidural local anesthesia: effect on ventilatory and airway occlusion pressure responses to CO₂." Anesthesiology **55**(4): 423-28.
- Douglas, N. J., White, D. P., Pickett, C. K., Weil, J. V. and Zwillich, C. W. (1982a). "Respiration during sleep in normal man." Thorax **37**: 840-44.
- Douglas, N. J., White, D. P., Weil, J. V., Pickett, C. K., Martin, R. J., Hudgel, D. W. and Zwillich, C. W. (1982b). "Hypoxic ventilatory response decreases during sleep in normal men." Am Rev Respir Dis **125**: 286-89.
- Douglas, N. J., White, D. P., Weil, J. V., Pickett, C. K. and Zwillich, C. W. (1982c). "Hypercapnic ventilatory response in sleeping adults." Am Rev Respir Dis **126**: 758-62.
- Douglas, N. J., White, D. P., Weil, J. V. and Zwillich, C. W. (1983). "Effect of breathing route on ventilation and ventilatory drive." Respir Physiol **51**: 209-18.
- Drummond, G. B. (1984). "Factors influencing the control of breathing." Int Anesthesiol Clin **22**: 59-74.
- Duffin, J. (1994). "Neural drives to breathing during exercise. [Review] [50 refs]." Can J Appl Physiol **19**(3): 289-304.
- Edelman, N. H., Epstein, P. E., Lahiri, S. and Cherniack, N. S. (1973). "Ventilatory responses to transient hypoxia and hypercapnia in man." Respir Physiol **17**(3): 302-14.
- Eldridge, F. L. (1975). "Relationship between respiratory nerve and muscle activity and muscle force output." J Appl Physiol **39**(4): 567-74.
- Eldridge, F. L. (1994). "Central integration of mechanisms in exercise hyperpnea." Med Sci Sports Exerc **26**(3): 319-27.
- Elliot, W. and Topulos, G. (1990). "The Influence of the Mechanics of Anesthesia Breathing Circuits on Respiratory Monitoring." Biomed Instrum & Technol: 260-65.
- Elliott, M. W., Mulvey, D. A., Green, M. and Moxham, J. (1993). "An evaluation of P_{0.1} measured in mouth and oesophagus, during carbon dioxide rebreathing in COPD." Eur Respir J **6**: 1055-59.
- Erlichman, J. S. and Leiter, J. C. (1997). "Comparative aspects of central CO₂ chemoreception." Respir Physiol **110**(2-3): 177-85.
- Evanich, M. J., Lopata, M. and Lourenco, R. V. (1976). "Phrenic nerve activity and occlusion pressure changes during CO₂ rebreathing in cats." J Appl Physiol **41**: 536-43.
- Fenn, W. O. and Craig, A. B. (1963). "Effect of CO₂ on respiration using a new method of administering CO₂." J Appl Physiol **18**(5): 1023-24.
- Fleming, P. J., Gilbert, R., Azaz, Y., Berry, P. J., Rudd, P. T., Stewart, A. and Hall, E. (1990). "Interaction between bedding and sleeping position in the sudden infant death syndrome: a population based case-control study." Bmj **301**(6743): 85-9.
- Forster, H. V. and Pan, L. G. (1994). "The role of the carotid chemoreceptors in the control of breathing during exercise. [Review] [50 refs]." Med Sci Sports Exerc **26**(3): 328-36.

- Frankovich, R. J. and Lebrun, C. M. (2000). "Menstrual cycle, contraception, and performance." *Clin Sports Med* **19**(2): 251-71.
- Gallagher, C. G., Sanii, R. and Younes, M. (1989). "Response of normal subjects to inspiratory resistive unloading." *J Appl Physiol* **66**: 1113-19.
- Gandia, F. and Blanco, J. (1992). "Evaluation of indexes predicting the outcome of ventilator weaning and value of adding supplemental inspiratory load." *Intensive Care Med* **18**(6): 327-33.
- Gelb, A. F., Klein, E., Schiffman, P., Lugliani, R. and Aronstam, P. (1977). "Ventilatory response and drive in acute and chronic obstructive pulmonary disease." *Am Rev Respir Dis* **116**(1): 9-16.
- Gelfand, R. and Lambertsen, C. J. (1973). "Dynamic respiratory response to abrupt change of inspired CO₂ at normal and high PO₂." *J Appl Physiol* **35**(6): 903-13.
- Giesbrecht, G. G. (1995). "The respiratory system in a cold environment." *Aviat Space Environ Med* **66**(9): 890-902.
- Gilbert, R., Auchincloss Jr, J. H., Brodsky, J. and Boden, W. (1972). "Changes in tidal volume, frequency, and ventilation induced by their measurement." *J Appl Physiol* **33**: 252-54.
- Goldberg, M. S. and Milic-Emili, J. (1977). "Effect of pentobarbital sodium on respiratory control in newborn rabbits." *J Appl Physiol* **42**(6): 845-51.
- Gooden, B. A. (1994). "Mechanism of the human diving response." *Integr Physiol Behav Sci* **29**(1): 6-16.
- Goodman, N. and Black, A. (1985). "Analyses of the ventilatory response to carbon dioxide. Implications for clinical research." *Br J Anaesth* **57**(3): 319-25.
- Goodman, N. and Curnow, J. (1985). "The ventilatory response to carbon dioxide. An analysis of data obtained by the rebreathing method." *Br J Anaesth* **57**(3): 311-18.
- Gray, P. A., Janczewski, W. A., Mellen, N., McCrimmon, D. R. and Feldman, J. L. (2001). "Normal breathing requires preBotzinger complex neurokinin-1 receptor-expressing neurons." *Nat Neurosci* **4**(9): 927-30.
- Gross, J. B., Blouin, R. T., Zandsberg, S., Conard, P. F. and Haussler, J. (1996). "Effect of flumazenil on ventilatory drive during sedation with midazolam and alfentanil." *Anesthesiology* **85**(4): 713-20.
- Grunstein, M. M., Younes, M. and Milic-Emili, J. (1973). "Control of tidal volume and respiratory frequency in anesthetized cats." *J Appl Physiol* **35**: 463-76.
- Grunstein, M. M., Derenne, J. P. and Milic-Emili, J. (1975). "Control of depth and frequency of breathing during baroreceptor stimulation in cats." *J Appl Physiol* **39**: 395-404.
- Hachenberg, T. (1996). "[Augmented spontaneous breathing]." *Anaesthesist* **45**(9): 839-55.
- Harper, R. M., Kinney, H. C., Fleming, P. J. and Thach, B. T. (2000a). "Sleep influences on homeostatic functions: implications for sudden infant death syndrome." *Respir Physiol* **119**(2-3): 123-32.
- Harper, R. M., Woo, M. A. and Alger, J. R. (2000b). "Visualization of sleep influences on cerebellar and brainstem cardiac and respiratory control mechanisms." *Brain Res Bull* **53**(1): 125-31.

- Hedner, J. (1983). "Neuropharmacological aspects of central respiratory regulation. An experimental study in the rat." *Acta Physiol Scand Suppl* **524**: 1-109.
- Heistad, D., Abboud, F. M., Mark, A. L. and Schmid, P. G. (1975). "Effect of baroreceptor activity on ventilatory response to chemoreceptor stimulation." *J Appl Physiol* **39**(3): 411-6.
- Hellström, L. G., Hallén, B. and Linnarsson, D. (1988). "Respiratory drive monitor integrated in a ventilator." *Phys Med Biol* **33 Suppl 1**: 219.
- Herrera, M., Blasco, J., Venegas, J., Barba, R., Doblaz, A. and Marquez, E. (1985). "Mouth occlusion pressure (P0.1) in acute respiratory failure." *Intensive Care Med* **11**: 134-39.
- Hida, W. (1999). "Role of ventilatory drive in asthma and chronic obstructive pulmonary disease. [Review] [32 refs]." *Current Opinion in Pulmonary Medicine* **5**(6): 339-43.
- Hilbert, G., Gruson, D., Portel, L., Vargas, F., Gbikpi-Benissan, G. and Cardinaud, J. P. (1998). "Airway occlusion pressure at 0.1 s (P0.1) after extubation: an early indicator of postextubation hypercapnic respiratory insufficiency." *Intensive Care Med* **24**(12): 1277-82.
- Hlastala, M. P., Wranne, B. and Lenfant, C. J. (1973). "Cyclical variations in FRC and other respiratory variables in resting man." *J Appl Physiol* **34**: 670-76.
- Holle, R. H., Schoene, R. B. and Pavlin, E. J. (1984). "Effect of respiratory muscle weakness on P0.1 induced by partial curarization." *J Appl Physiol* **57**(4): 1150-7.
- Holliday, J. E. and Veremakis, C. (1999). "Reduction in ventilator response to CO2 with relaxation feedback during CO2 rebreathing in normal adults." *Chest* **115**(5): 1285-92.
- Horn, E. M. and Waldrop, T. G. (1998). "Suprapontine control of respiration." *Respir Physiol* **114**(3): 201-11.
- Hudgel, D. W., Capehart, M. and Hirsch, J. E. (1979). "Ventilation response and drive during hypoxia in adult patients with asthma." *Chest* **76**(3): 294-9.
- Hunt, C. E. (1992). "The cardiorespiratory control hypothesis for sudden infant death syndrome." *Clin Perinatol* **19**(4): 757-71.
- Im Hof, V., West, P. and Younes, M. (1986). "Steady-state response of normal subjects to inspiratory resistive load." *J Appl Physiol* **60**: 1471-81.
- Iscoe, S. (1998). "Control of abdominal muscles." *Prog Neurobiol* **56**(4): 433-506.
- Jacobi, M. S., Iyawe, V. I., Patil, C. P., Cummin, A. R. and Saunders, K. B. (1987). "Ventilatory responses to inhaled carbon dioxide at rest and during exercise in man." *Clin Sci (Lond)* **73**(2): 177-82.
- Jacobi, M. S., Patil, C. P. and Saunders, K. B. (1989a). "Transient, steady-state and rebreathing responses to carbon dioxide in man, at rest and during light exercise." *J Physiol (Lond)* **411**: 85-96.
- Jacobi, M. S., Patil, C. P. and Saunders, K. B. (1989b). "The transient ventilatory response to carbon dioxide at rest and in exercise in man." *Respir Physiol* **77**(2): 225-37.
- Johnson, D. C. and Kazemi, H. (1994). "Central control of ventilation in neuromuscular disease. [Review] [85 refs]." *Clin Chest Med* **15**(4): 607-17.

- Johnson, S. M., Koshiya, N. and Smith, J. C. (2001). "Isolation of the kernel for respiratory rhythm generation in a novel preparation: the pre-Botzinger complex "island"." *J Neurophysiol* **85**(4): 1772-6.
- Jordan, C. (1981). "Automatic method for measuring mouth occlusion pressure response to carbon dioxide inhalation." *Med Biol Eng Comput* **19**: 279-86.
- Katz-Salamon, M. and Milerad, J. (1998). "The divergent ventilatory and heart rate response to moderate hypercapnia in infants with apnoea of infancy." *Arch Dis Child* **79**(3): 231-36.
- Kelsen, S. G., Altose, M. D., Stanley, N. N., Levinson, R. S., Cherniack, N. S. and Fishman, A. P. (1976). "Effect of hypoxia on the pressure developed by inspiratory muscles during airway occlusion." *J Appl Physiol* **40**: 372-78.
- King, E. D., O'Donnell, C. P., Smith, P. L. and Schwartz, A. R. (2000). "A model of obstructive sleep apnea in normal humans. Role of the upper airway." *Am J Respir Crit Care Med* **161**(6): 1979-84.
- Koshiya, N. and Smith, J. C. (1999). "Neuronal pacemaker for breathing visualized in vitro." *Nature* **400**(6742): 360-3.
- Kronenberg, R., Hamilton, F. N., Gabel, R., Hickey, R., Read, D. J. and Severinghaus, J. (1972). "Comparison of three methods for quantitating respiratory response to hypoxia in man." *Respir Physiol* **16**(1): 109-25.
- Kryger, M. H., Yacoub, O. and Anthonisen, N. R. (1975). "Effect of inspiratory resistance of occlusion pressure in hypoxia and hypercapnia." *Respir Physiol* **24**: 241-48.
- Kuhlen, R., Hausmann, S., Pappert, D., Slama, K., Rossaint, R. and Falke, K. (1995). "A new method for P_{0.1} measurement using standard respiratory equipment." *Intensive Care Med* **21**: 554-60.
- Kuhlen, R., Mohnhaupt, R., Slama, K., Hausmann, S., Pappert, D., Rossaint, R. and Falke, K. (1996). "Validation and clinical application of a continuous P_{0.1} measurement using standard respiratory equipment." *Technol Health Care* **4**(4): 415-24.
- Launois, S., Clergue, F., Medrano, G., Similowski, T., Aubier, M., Murciano, D., Pariente, R. and Derenne, J. P. (1991). "[The control of respiration in pulmonary fibrosis. The effect of O₂ and CO₂]." *Rev Mal Respir* **8**(1): 67-73.
- Lederer, D. H., Altose, M. D., Kelsen, S. G. and Cherniack, N. S. (1977). "Comparison of occlusion pressure and ventilatory responses." *Thorax* **32**: 212-20.
- Lenfant, C. (1967). "Time-dependent variations of pulmonary gas exchange in normal man at rest." *J Appl Physiol* **22**: 675-84.
- Lewis, N. C., McBride, J. T. and Brooks, J. G. (1988). "Ventilatory chemosensitivity in parents of infants with sudden infant death syndrome." *J Pediatr* **113**(2): 307-11.
- Lind, F. G., Truve, A. B. and Lindborg, B. P. (1984). "Microcomputer-assisted on-line measurement of breathing pattern and occlusion pressure." *J Appl Physiol* **56**(1): 235-9.
- Lindahl, S. G. and Johannesson, G. P. (1987). "Ventilatory CO₂ response, respiratory drive and timing in children anaesthetized with halothane, enflurane or isoflurane." *Eur J Anaesthesiol* **4**(5): 313-26.

- Lindgren, A. C., Hagenas, L., Muller, J., Blichfeldt, S., Rosenborg, M., Brismar, T. and Ritzen, E. M. (1997). "Effects of growth hormone treatment on growth and body composition in Prader-Willi syndrome: a preliminary report. The Swedish National Growth Hormone Advisory Group." Acta Paediatr Suppl **423**: 60-2.
- Lindgren, A. C., Hagenas, L., Muller, J., Blichfeldt, S., Rosenborg, M., Brismar, T. and Ritzen, E. M. (1998). "Growth hormone treatment of children with Prader-Willi syndrome affects linear growth and body composition favourably." Acta Paediatr **87**(1): 28-31.
- Lindsey, B. G. (2001). "How is the respiratory central pattern generator configured and reconfigured? A workshop summary." Adv Exp Med Biol **499**: 179-84.
- Linnarsson, D. and Hesser, C. M. (1978). "Dissociated ventilatory and central respiratory responses to CO₂ at raised N₂ pressure." J Appl Physiol **45**(5): 756-61.
- Lopata, M., Evanich, M. J. and Lourenco (1976). "The electromyogram of the diaphragm in the investigation of human regulation of ventilation." Chest **70**(1 Suppl): 162-5.
- Lopata, M., Evanich, M. J. and Lourenco, R. V. (1977a). "Relationship between mouth occlusion pressure and electrical activity of the diaphragm: effects of flow-resistive loading." Am Rev Respir Dis **116**: 449-55.
- Lopata, M., La Fata, J., Evanich, M. J. and Lourenco, R. V. (1977b). "Effects of flow-resistive loading on mouth occlusion pressure during CO₂ rebreathing." Am Rev Respir Dis **115**: 73-81.
- Lopata, M., Evanich, M. J., Onal, E., Zubillaga, G. and Lourenco, R. V. (1978). "Airway occlusion pressure and respiratory nerve and muscle activity in studies of respiratory control." Chest **73**: 285-86.
- Lourenco, R. V. and Miranda, J. M. (1968). "Drive and performance of the ventilatory apparatus in chronic obstructive lung disease." N Engl J Med **279**(2): 53-59.
- Macnaughton, P. D. (1997). "Assessment of lung function in the ventilated patient [published erratum appears in Intensive Care Med 1997 Oct;23(10):1103]. [Review] [69 refs]." Intensive Care Med **23**(8): 810-18.
- Malhotra, A., Pillar, G., Fogel, R. B., Beauregard, J., Edwards, J. K., Slamowitz, D. I., Shea, S. A. and White, D. P. (2000). "Genioglossal but not palatal muscle activity relates closely to pharyngeal pressure." Am J Respir Crit Care Med **162**(3 Pt 1): 1058-62.
- Malhotra, A., Pillar, G., Fogel, R. B., Edwards, J. K., Ayas, N., Akaoshi, T., Hess, D. and White, D. P. (2002). "Pharyngeal pressure and flow effects on genioglossus activation in normal subjects." Am J Respir Crit Care Med **165**(1): 71-7.
- Malkoff, M. D. and Borel, C. O. (1994). "Central nervous system modulation of respiratory function in the critically ill. [Review] [63 refs]." New Horiz **2**(4): 419-25.
- Mancebo, J., Albaladejo, P., Touchard, D., Bak, E., Subirana, M., Lemaire, F., Harf, A. and Brochard, L. (2000). "Airway occlusion pressure to titrate positive end-expiratory pressure in patients with dynamic hyperinflation." Anesthesiology **93**(1): 81-90.

- Marazzini, L., Galli, G., Vezzoli, F. and Longhini, E. (1977). "Drive and performance of ventilatory system during rebreathing." *Respiration* **34**(1): 50-60.
- Marazzini, L., Cavestri, R., Gori, D., Gatti, L. and Longhini, E. (1978). "Difference between mouth and esophageal occlusion pressure during CO₂ rebreathing in chronic obstructive pulmonary disease." *Am Rev Respir Dis* **118**(6): 1027-33.
- Marcus, C. L. (2000). "Pathophysiology of childhood obstructive sleep apnea: current concepts. [Review] [72 refs]." *Respir Physiol* **119**(2-3): 143-54.
- Marin, J. M., Montes de Oca, M., Rassulo, J. and Celli, B. R. (1999). "Ventilatory drive at rest and perception of exertional dyspnea in severe COPD." *Chest* **115**(5): 1293-300.
- Marini, J. J., Rodriguez, R. M. and Lamb, V. (1986). "The inspiratory workload of patient-initiated mechanical ventilation." *Am Rev Respir Dis* **134**(5): 902-9.
- Maskrey, M. (1995). "Influence of body temperature on responses to hypoxia and hypercapnia: implications for SIDS." *Clin Exp Pharmacol Physiol* **22**(8): 527-32.
- Matthews, A. W. and Howell, J. B. (1975). "The rate of isometric inspiratory pressure development as a measure of responsiveness to carbon dioxide in man." *Clin Sci Mol Med* **49**: 57-68.
- Maxwell, D. L., Cover, D. and Hughes, J. M. (1985). "Effect of respiratory apparatus on timing and depth of breathing in man." *Respir Physiol* **61**: 255-64.
- McCrimmon, D. R., Monnier, A., Ptak, K., Zummo, G., Zhang, Z. and Alheid, G. F. (2001). "Respiratory rhythm generation: preBotzinger neuron discharge patterns and persistent sodium current." *Adv Exp Med Biol* **499**: 147-52.
- McNicholas, W. T. (1997). "Impact of sleep in respiratory failure." *Eur. Respir. J.* **10**(4): 920-33.
- Mekjavic, I. B., La Prairie, A., Burke, W. and Lindborg, B. (1987). "Respiratory drive during sudden cold water immersion." *Respir Physiol* **70**(1): 121-30.
- Mergoni, M., Costa, A., Primavera, S., Salvadori, A., Saccani, A. and Zuccoli, P. (1996). "[Assessment of various new predictive parameters of the outcome of mechanical ventilation weaning]. [Italian]." *Minerva Anesthesiol* **62**(5): 153-64.
- Meza, S., Giannouli, E. and Younes, M. (1998). "Control of breathing during sleep assessed by proportional assist ventilation." *J Appl Physiol* **84**(1): 3-12.
- Milerad, J. and Hellström, L. G. (1993). Fathers of victims of sudden infant death syndrome (SIDS) fail to maintain ventilation during loaded breathing. The Society for Pediatric Research Annual Meeting, Whashington D.C., The American Pediatric Society.
- Milic-Emili, J. and Tyler, J. M. (1963). "Relation between work output of the respiratory muscles and end tidal CO₂ tension." *J Appl Physiol* **18**: 497-504.
- Milic-Emili, J., Whitelaw, W. A. and Derenne, J. P. (1975). "New tests to assess lung function: occlusion pressure--a simple measure of the respiratory center's output." *N Engl J Med* **293**(20): 1029-30.

- Milic-Emili, J. and Grunstein, M. M. (1976). "Drive and timing components of ventilation." *Chest* **70**: 131-33.
- Milic-Emili, J., Anthonisen, N., Bryan, A., Cambell, E., Lourenco, R., Remmers, J., Saunders, M. and Zechman, F. (1977). "Measurements of Respiratory Pressures in the Assessment of Ventilatory Drive." *Am Rev Respir Dis* **115**: 365.
- Mitchell, G. S., Powell, F. L., Hopkins, S. R. and Milsom, W. K. (2001). "Time domains of the hypoxic ventilatory response in awake ducks: episodic and continuous hypoxia." *Respir Physiol* **124**(2): 117-28.
- Montes de Oca, M. and Celli, B. R. (1998). "Mouth occlusion pressure, CO₂ response and hypercapnia in severe chronic obstructive pulmonary disease." *Eur Respir J* **12**(3): 666-71.
- Montgomery, A. B., Holle, R. H., Neagley, S. R., Pierson, D. J. and Schoene, R. B. (1987). "Prediction of successful ventilator weaning using airway occlusion pressure and hypercapnic challenge." *Chest* **91**(4): 496-9.
- Morisot, P., Dessanges, J. F., Regnard, J. and Lockhart, A. (1989). "Ventilatory response to carbon dioxide during extradural anaesthesia with lignocaine and fentanyl." *Br J Anaesth* **63**(1): 97-102.
- Morrell, M. J., Heywood, P., Moosavi, S. H., Stevens, J. and Guz, A. (2001). "Central chemosensitivity and breathing asleep in unilateral medullary lesion patients: comparisons to animal data." *Respir Physiol* **129**(1-2): 269-77.
- Morrill, C. G., Dickey, D. W. and Cropp, G. J. (1981). "Ventilatory response and drive of asthmatic children to alveolar hypoxia." *Pediatr Res* **15**(12): 1520-4.
- Mortola, J. P. and Frappell, P. B. (2000). "Ventilatory responses to changes in temperature in mammals and other vertebrates." *Annu Rev Physiol* **62**: 847-74.
- Mukhtar, M. R. and Patrick, J. M. (1986). "Ventilatory drive during face immersion in man." *J Physiol* **370**: 13-24.
- Murat, I., Dubois, M. C. and Piat, V. (1995). "[Sevoflurane]." *Ann Fr Anesth Reanim* **14**(6): 489-501.
- Murciano, D., Aubier, M., Bussi, S., Derenne, J. P., Pariente, R. and Milic-Emili, J. (1982). "Comparison of esophageal, tracheal, and mouth occlusion pressure in patients with chronic obstructive pulmonary disease during acute respiratory failure." *Am Rev Respir Dis* **126**(5): 837-41.
- Mårzell, A. (1999). Algorithm for Occlusion Pressure Measurement. An implementation in Siemens' Servo Ventilator 300. *Division of Medical Engineering*. Stockholm, Karolinska Institutet: 75.
- Nachmanoff, D. B., Panigrahy, A., Filiano, J. J., Mandell, F., Sleeper, L. A., Valdes-Dapena, M., Krous, H. F., White, W. F. and Kinney, H. C. (1998). "Brainstem 3H-nicotine receptor binding in the sudden infant death syndrome." *J Neuropathol Exp Neurol* **57**(11): 1018-25.
- Nattie, E. (1999). "CO₂, brainstem chemoreceptors and breathing." *Prog Neurobiol* **59**(4): 299-331.
- Nattie, E. E. (2001a). "Central chemosensitivity, sleep, and wakefulness." *Respir Physiol* **129**(1-2): 257-68.

- Nattie, E. E. (2001b). "Chemoreception and tonic drive in the retrotrapezoid nucleus (RTN) region of the awake rat: bicuculline and muscimol dialysis in the RTN." *Adv Exp Med Biol* **499**: 27-32.
- Nattie, E. E. and Prabhakar, N. R. (2001). "Peripheral and central chemosensitivity: multiple mechanisms, multiple sites? A workshop summary." *Adv Exp Med Biol* **499**: 73-80.
- Nava, S., Zanotti, E. and Rubini, F. (1994). "Weaning and outcome from mechanical ventilation." *Monaldi Arch Chest Dis* **49**(6): 530-32.
- Neumeister, W., Rasche, K., Maas, P., Monnerjahn, C., Singh, B. and Schultze-Werninghaus, G. (1996). "[Reproducibility of computer-assisted mouth occlusion pressure measurements]." *Med Klin* **91 Suppl 2**: 73-5.
- Neumeister, W., Kuhlemann, H., Bauer, T., Krause, S., Schultze-Werninghaus, G. and Rasche, K. (1999). "[Effect of acupuncture on quality of life, mouth occlusion pressures and lung function in COPD]." *Med Klin* **94**(1 Spec No): 106-9.
- Nishino, T. and Kochi, T. (1994). "Breathing route and ventilatory responses to inspiratory resistive loading in humans." *American Journal of Respiratory & Critical Care Medicine* **150**: 742-46.
- Onimaru, H. (1995). "Studies of the respiratory center using isolated brainstem-spinal cord preparations." *Neurosci Res* **21**(3): 183-90.
- O'Regan, R. G. and Majcherczyk, S. (1982). "Role of peripheral chemoreceptors and central chemosensitivity in the regulation of respiration and circulation." *J Exp Biol* **100**: 23-40.
- Patel, A. J. and Honore, E. (2001). "Molecular physiology of oxygen-sensitive potassium channels." *Eur Respir J* **18**(1): 221-7.
- Paterson, D. J. (1997). "Potassium and breathing in exercise." *Sports Med* **23**(3): 149-63.
- Patil, C. P., Saunders, K. B. and Sayers, B. M. (1990). "Timing of deep breaths during rest and light exercise in man." *Clin Sci (Lond)* **78**(6): 573-8.
- Pengelly, L. D., Alderson, A. M. and Milic-Emili, J. (1971). "Mechanics of the diaphragm." *J Appl Physiol* **30**(6): 797-805.
- Perrigault, P. F., Pouzeratte, Y. H., Jaber, S., Capdevila, X. J., Hayot, M., Boccarda, G., Ramonatxo, M. and Colson, P. (1999). "Changes in occlusion pressure (P_{0.1}) and breathing pattern during pressure support ventilation." *Thorax* **54**(2): 119-23.
- Petros, A. J., Lamond, C. T. and Bennett, D. (1993). "The Bicare pulmonary monitor. A device to assess the work of breathing while weaning from mechanical ventilation." *Anaesthesia* **48**(11): 985-8.
- Pillar, G., Malhotra, A., Fogel, R., Beauregard, J., Schnall, R. and White, D. P. (2000). "Airway mechanics and ventilation in response to resistive loading during sleep: influence of gender." *Am J Respir Crit Care Med* **162**(5): 1627-32.
- Pimmel, R. L. and Eldridge, F. L. (1979). "Difference between occluded airway pressure and generated muscle pressure." *Ann Biomed Eng* **7**(1): 67-72.
- Poon, C. S., Ward, S. A. and Whipp, B. J. (1987). "Influence of inspiratory assistance on ventilatory control during moderate exercise." *J Appl Physiol* **62**: 551-60.

- Poon, C. S. (1989). "Effects of inspiratory resistive load on respiratory control in hypercapnia and exercise." *J Appl Physiol* **66**: 2391-99.
- Pourriat, J. L., Baud, M., Lamberto, C., Fournier, J. L. and Cupa, M. (1994). "Measurement of CO₂ response with the breath-by-breath automatic acquisition of the breathing pattern and occlusion pressure." *J Clin Monit* **10**: 26-34.
- Powell, F. L., Milsom, W. K. and Mitchell, G. S. (1998). "Time domains of the hypoxic ventilatory response." *Respir Physiol* **112**(2): 123-34.
- Rajagopal, K. R., Abbrecht, P. H. and Tellis, C. J. (1984). "Control of breathing in obstructive sleep apnea." *Chest* **85**(2): 174-80.
- Rathgeber, J. (1997). "[Ventilation modes and strategies in intensive care medicine]." *Anaesthesiol Reanim* **22**(1): 4-14.
- Read, D. J. (1967). "A clinical method for assessing the ventilatory response to carbon dioxide." *Australas Ann Med* **16**(1): 20-32.
- Read, D. J. and Leigh, J. (1967). "Blood-brain tissue Pco₂ relationships and ventilation during rebreathing." *J Appl Physiol* **23**(1): 53-70.
- Rebuck, A. and Campbell, E. (1974). "A clinical method for assessing the ventilatory response to hypoxia." *Am Rev Respir Dis* **109**(3): 345-50.
- Rekling, J. C. and Feldman, J. L. (1998). "PreBotzinger complex and pacemaker neurons: hypothesized site and kernel for respiratory rhythm generation." *Annu Rev Physiol* **60**: 385-405.
- Remmers, J. E., Torgerson, C., Harris, M., Perry, S. F., Vasilakos, K. and Wilson, R. J. (2001). "Evolution of central respiratory chemoreception: a new twist on an old story." *Respir Physiol* **129**(1-2): 211-7.
- Reynolds, W. J., Milhorn, H. T. J. and Holloman, G. H. J. (1972). "Transient ventilatory response to graded hypercapnia in man." *J. Appl. Physiol.* **33**(1): 47-54.
- Rhoades, R. and Tanner, G. (1995). *The Control of Breathing. Medical Physiology.* Baltimore, Lippincott, Williams and Wilkins: 401-14.
- Richter, D. W., Ballanyi, K. and Schwarzscher, S. (1992). "Mechanisms of respiratory rhythm generation." *Curr Opin Neurobiol* **2**(6): 788-93.
- Rigg, J. R. A., Rebuck, A. S. and Cambell, E. J. M. (1974). "Effect of posture on the ventilatory response to CO₂." *J Appl Physiol* **37**: 487-90.
- Sandek, K., Bratel, T., Hellstrom, G. and Lagerstrand, L. (2001). "Ventilation-perfusion inequality and carbon dioxide sensitivity in hypoxaemic chronic obstructive pulmonary disease (COPD) and effects of 6 months of long-term oxygen treatment (LTOT)." *Clin Physiol* **21**(5): 584-93.
- Sanders, J. S., Berman, T. M., Bartlett, M. M. and Kronenberg, R. S. (1980). "Increased hypoxic ventilatory drive due to administration of aminophylline in normal men." *Chest* **78**(2): 279-82.
- Sant'Ambrogio, G., Tsubone, H. and Sant'Ambrogio, F. B. (1995). "Sensory information from the upper airway: role in the control of breathing. [Review] [59 refs]." *Respir Physiol* **102**(1): 1-16.
- Sassoon, C. S., Te, T. T., Mahutte, C. K. and Light, R. W. (1987). "Airway occlusion pressure. An important indicator for successful weaning in patients with chronic obstructive pulmonary disease." *Am Rev Respir Dis* **135**(1): 107-13.

- Sassoon, C. S. and Mahutte, C. K. (1993). "Airway occlusion pressure and breathing pattern as predictors of weaning outcome." Am Rev Respir Dis **148**: 860-66.
- Scano, G., Gigliotti, F., Duranti, R., Gorini, M., Fanelli, A. and Marconi, G. (1993). "Control of breathing in patients with neuromuscular diseases [see comments]. [Review] [23 refs]." Monaldi Arch Chest Dis **48**(1): 87-91.
- Schlaefke, M. E. (1981). "Central chemosensitivity: a respiratory drive." Rev Physiol Biochem Pharmacol **90**: 171-244.
- Schwartz, A. R., Smith, P. L., Wise, R. A., Gold, A. R. and Permutt, S. (1988). "Induction of upper airway occlusion in sleeping individuals with subatmospheric nasal pressure." J Appl Physiol **64**(2): 535-42.
- Scott, G. C. and Burki, N. K. (1990). "The relationship of resting ventilation to mouth occlusion pressure. An index of resting respiratory function." Chest **98**(4): 900-6.
- Scott, G. C. and Piquette, C. A. (1993). "Use of a face mask in the measurement of resting ventilatory parameters and mouth occlusion pressures." Sleep **16**(7): 668-70.
- Scott, J. C., Ponganis, K. V. and Stanski, D. R. (1985). "EEG quantitation of narcotic effect: the comparative pharmacodynamics of fentanyl and alfentanil." Anesthesiology **62**(3): 234-41.
- Series, F., Cormier, Y., Desmeules, M. and La Forge, J. (1989a). "Influence of respiratory drive on upper airway resistance in normal men." J Appl Physiol **66**(3): 1242-49.
- Series, F., Cormier, Y., Desmeules, M. and La Forge, J. (1989b). "Effects of respiratory drive on upper airways in sleep apnea patients and normal subjects." J Appl Physiol **67**(3): 973-9.
- Shafer, S. L., Siegel, L. C., Cooke, J. E. and Scott, J. C. (1988). "Testing computer-controlled infusion pumps by simulation." Anesthesiology **68**(2): 261-6.
- Shea, S. A. (1997). "Life without ventilatory chemosensitivity." Respir Physiol **110**(2-3): 199-210.
- Shirasawa, S., Arata, A., Onimaru, H., Roth, K. A., Brown, G. A., Horning, S., Arata, S., Okumura, K., Sasazuki, T. and Korsmeyer, S. J. (2000). "Rnx deficiency results in congenital central hypoventilation." Nat Genet **24**(3): 287-90.
- Smith, T. F. and Hudgel, D. W. (1980). "Decreased ventilation response to hypoxia in children with asthma." J Pediatr **97**(5): 736-41.
- Solomon, I. C. (2000). "Excitation of phrenic and sympathetic output during acute hypoxia: contribution of medullary oxygen detectors." Respir Physiol **121**(2-3): 101-17.
- Soma, K., Otsuka, H. and Tomita, T. (1988). "Mouth occlusion pressure as a useful indicator for weaning from mechanical ventilation." Tohoku J Exp Med **156 Suppl**: 181-87.
- Spengler, C. M., Gozal, D. and Shea, S. A. (2001). "Chemoreceptive mechanisms elucidated by studies of congenital central hypoventilation syndrome." Respir Physiol **129**(1-2): 247-55.
- St John, W. M. (1990). "Neurogenesis, control, and functional significance of gasping." J Appl Physiol **68**(4): 1305-15.

- St John, W. M. (1996). "Medullary regions for neurogenesis of gasping: noeud vital or noeuds vitals?" *J Appl Physiol* **81**(5): 1865-77.
- Strachova, Z. and Plum, F. (1973). "Reproducibility of the rebreathing carbon dioxide response test using an improved method." *Am Rev Respir Dis* **107**: 864-69.
- Strauser, L. M., Helikson, M. A. and Tobias, J. D. (1999). "Anesthetic care for the child with congenital central alveolar hypoventilation syndrome (Ondine's curse)." *J Clin Anesth* **11**(5): 431-7.
- Swanson, G. and Bellville, J. (1975). "Step changes in end-tidal CO₂: methods and implications." *J Appl Physiol* **39**(3): 377-85.
- Tan, C. S. and Simmons, D. H. (1981). "Effect of assisted ventilation on respiratory drive of normal anesthetized dogs." *Respir Physiol* **43**(3): 287-97.
- Tanaka, A., Isono, S., Sato, J. and Nishino, T. (2001). "Effects of minor surgery and endotracheal intubation on postoperative breathing patterns in patients anaesthetized with isoflurane or sevoflurane." *Br J Anaesth* **87**(5): 706-10.
- Tardif, C., Bonmarchand, G., Gibon, J. F., Hellot, M. F., Leroy, J., Pasquis, P., Milic-Emili, J. and Derenne, J. P. (1993). "Respiratory response to CO₂ in patients with chronic obstructive pulmonary disease in acute respiratory failure [see comments]." *Eur Respir J* **6**(5): 619-24.
- Tatsumi, K. (1999). "[Effects of female hormones on respiratory and cardiovascular regulation]." *Nihon Kokyuki Gakkai Zasshi* **37**(5): 359-67.
- Thoby-Brisson, M. and Ramirez, J. M. (2001). "Identification of two types of inspiratory pacemaker neurons in the isolated respiratory neural network of mice." *J Neurophysiol* **86**(1): 104-12.
- Tobin, M. J. (1988). "Respiratory monitoring in the intensive care unit. [Review] [173 refs]." *Am Rev Respir Dis* **138**(6): 1625-42.
- Vallverdu, I., Calaf, N., Subirana, M., Net, A., Benito, S. and Mancebo, J. (1998). "Clinical characteristics, respiratory functional parameters, and outcome of a two-hour T-piece trial in patients weaning from mechanical ventilation." *Am J Respir Crit Care Med* **158**(6): 1855-62.
- van den Aardweg, J. G. and Karemaker, J. M. (1991). "Respiratory variability and associated cardiovascular changes in adults at rest." *Clin Physiol* **11**(2): 95-118.
- Ward, S. A., Agleh, K. A. and Poon, C. S. (1981). "Breath-to-breath monitoring of inspiratory occlusion pressures in humans." *J Appl Physiol* **51**: 520-23.
- Ward, S. A. (2000). "Control of the exercise hyperpnoea in humans: a modeling perspective." *Respir Physiol* **122**(2-3): 149-66.
- Weil, J. V., Byrne-Quinn, E., Sodal, I. E., Friesen, W. O., Underhill, B., Filley, G. F. and Grover, R. F. (1970). "Hypoxic ventilatory drive in normal man." *J Clin Invest* **49**(6): 1061-72.
- Weissman, C., Askanazi, J., Milic-Emili, J. and Kinney, J. M. (1984). "Effect of respiratory apparatus on respiration." *J Appl Physiol* **57**(2): 475-80.
- Western, P. J. and Patrick, J. M. (1988). "Effects of focusing attention on breathing with and without apparatus on the face." *Respir Physiol* **72**(1): 123-30.
- Wheatley, J. R. and Amis, T. (1998). "Mechanical properties of the upper airway." *Current Opinion in Pulmonary Medicine* **4**(6): 363-69.

- White, D. P. (1986). "Occlusion pressure and ventilation during sleep in normal humans." J Appl Physiol **61**(4): 1279-87.
- Whitelaw, W. and Milic-Emili, J. (1973). "A New Method for Evaluating Respiratory Centre Output." The Physiologist **16**: 486.
- Whitelaw, W. A., Derenne, J. P. and Milic-Emili, J. (1975). "Occlusion pressure as a measure of respiratory center output in conscious man." Respir Physiol **23**: 181-99.
- Whitelaw, W. A. and Derenne, J. P. (1993). "Airway occlusion pressure." J Appl Physiol **74**: 1475-83.
- Wiegand, L., Zwillich, C. W. and White, D. P. (1988). "Sleep and the ventilatory response to resistive loading in normal men." J Appl Physiol **64**(3): 1186-95.
- Wilson, R. J., Harris, M. B., Remmers, J. E. and Perry, S. F. (2000). "Evolution of air-breathing and central CO₂/H⁺ respiratory chemosensitivity: new insights from an old fish?" J Exp Biol **203 Pt 22**: 3505-12.
- Wolfe, L. A., Kemp, J. G., Heenan, A. P., Preston, R. J. and Ohtake, P. J. (1998). "Acid-base regulation and control of ventilation in human pregnancy." Can J Physiol Pharmacol **76**(9): 815-27.
- von Euler, C. (1977). "The functional organization of the respiratory phase-switching mechanisms." Fed Proc **36**(10): 2375-80.
- Zackon, H., Despas, P. J. and Anthonisen, N. R. (1976). "Occlusion pressure responses in asthma and chronic obstructive pulmonary disease." Am Rev Respir Dis **114**(5): 917-27.